

# UNIT 3

# PRESSURE

**Unit outcomes: After completing this unit you should be able to:**

- ✓ understand concepts related to pressure;
- ✓ develop skill of manipulating problems related to pressure;
- ✓ appreciate the interrelatedness of all things;
- ✓ use a wide range of possibilities for developing knowledge of the major concepts with in physics.

## Introduction

In grade 7 physics, you learnt about force and its effects. Do you remember some of the effects of forces? In this unit you will study another effect of force known as **pressure**.

You begin first studying the concept of pressure using solid materials. Then you will learn about liquid pressure, atmospheric pressure, measuring atmospheric pressure, Pascal's principle and finally some applications of pressure.

### 3.1 Definition and Unit of Pressure

#### Activity 3.1

Discuss the following questions with your friends or parents.

1. What is a force? What is an area?
2. Explain the effect of force on a unit area.
3. What do you call this effect?

In Activity 3.1, most likely you recognized the difference between pressure and force.

Force is a push or a pull which changes the shape of a body; but pressure means force per unit area. Without changing the magnitude of the force you can have different pressures, just by changing the area on which the force acts. (see Fig 3.1).

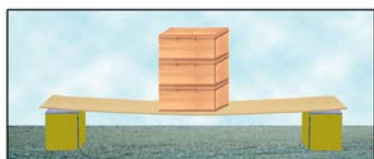

a) Vertically arranged blocks



b) Horizontally arranged blocks

Fig 3.1. Effects of area on pressure

#### Activity 3.2 Observing the dependence of pressure on an area

*Material required:* blocks of wood (or books), a ruler, and a supporting body

*Procedure:* Place the ruler between two supporting bodies.

- Place the blocks of wood, one by one on the ruler. (Fig 3.1) the blocks could be placed
  - a) Vertically (Fig. 3.1a) one over the other and the effect of the weight of the blocks on the ruler will be seen. What do you observe?
  - b) Horizontally (Fig. 3.1b) next to each other. Compare the effect of the weight of the blocks on the ruler. In which cases is the ruler bent more? Explain the reason.
- What can you conclude about the dependence of pressure on an area?

From Activity 3.2 you have noticed that, the pressure exerted by the block of wood on the ruler depends on the area on which the blocks were resting. The pressure is higher when the blocks are vertically placed than when they are arranged horizontally.

Pressure is an effect which occurs when a force is applied on a surface. Pressure is the amount of force acting on a unit area. The symbol of pressure is P.

$$\text{Pressure} = \frac{\text{Force exerted}}{\text{Area}} \Rightarrow P = \frac{F}{A}$$

The SI unit of pressure is Newton per square meter ( $\text{N/m}^2$ ), and this unit is also called Pascal and is represented by  $\text{Pa}$ .

Where  $1 \text{ Pa} = 1 \text{ N/m}^2$ .

*Other non-SI units are the bar, millibar and the torr.*

*1 millibar = 100pa*

*1 bar = 100,000pa*

*1 torr = 1mm of Hg  
= 0.1 cm of Hg*

*1.01 bar=1010 millibars*

*= 760 torrs*

*= 101,000 pa and it is*

*known as Standard Atmospheric Pressure (SAP).*

From the definition of pressure one can understand that the pressure of the system increases with an increase of a force.

From the Activity 3.2; you have observed that pressure depends on the area on which the force is applied.

### Challenging questions

1. Do you know an elephant? What about its hoof? Is it large or small?
2. What would happen to the elephant if it had a small hoof similar to a goat?

Nature seems to be aware of the factors affecting pressure. The hoof of an elephant covers a wide area. When it walks, its large weight is spread over a wide area of its hoof. So, its pressure or force per unit area is less. This helps the elephant to walk over soft ground without sinking much into it.

### Dimension of pressure

If  $F$  is in  $N$  and  $N = kg\ m/s^2$ , its dimension is  $[MLT^{-2}]$ , and if  $A$  is in  $m^2$  its dimension is  $[L^2]$

Therefore, the dimension of pressure is  $\left[\frac{MLT^{-2}}{L^2}\right] = [ML^{-1}T^{-2}]$

### Challenging question

Can you explain why tractors have tires of large area than an automobile?

#### Examples 3.1

- Calculate the pressure exerted at a point while a nail tip of area  $0.1\text{cm}^2$  is hammered into a wooden block with a force of  $20\text{N}$ .

| Given  | Required | Solution  |
|--|----------|---|
| $F = 20\text{N}$<br>$A = 0.1\text{cm}^2 = 0.00001\text{m}^2$ | $P = ?$  | $P = \frac{F}{A} = \frac{20\text{N}}{0.00001\text{m}^2}$<br>$= 2,000,000\text{N/m}^2$ or $2,000,000\text{pa}$ |

- What force is required to produce a pressure of  $20,000\text{N/m}^2$  when the surface area is  $2\text{m}^2$ ?

| Given   | Required | Solution   |
|---|----------|--|
| $P = 20,000\text{N/m}^2$<br>$A = 2\text{m}^2$ | $F = ?$  | $P = \frac{F}{A} \Rightarrow F = P \times A$<br>$= 20,000\frac{\text{N}}{\text{m}^2} \times 2\text{m}^2$<br>$\Rightarrow F = 40,000\text{N}$ |

- A rectangular block of mass  $50\text{kg}$  lies with a side  $2\text{m}$  by  $1\text{m}$  on a table. What is the pressure exerted by its weight on the table? ( Fig 3.2)

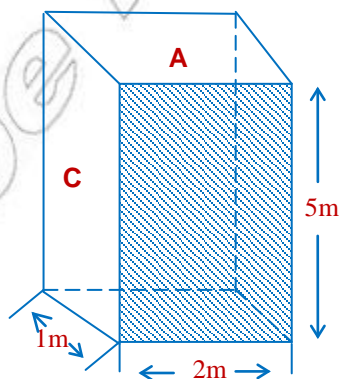

Fig 3.2 A block of sides  $1\text{m} \times 2\text{m} \times 5\text{m}$

## Given

Mass of block = 50 kg  
 Sides of block = 2m × 1m × 5m  
 $g = 10 \text{ m/s}^2$

## Required

$P_A = ?$

## Solution

From your discussion in unit one, you already learnt how to calculate the area of any surface. Hence area of the block on surface 'A' =  $1\text{m} \times 2\text{m} = 2\text{m}^2$

Weight of the block  $W = m_b \times g = 50\text{kg} \times 10\text{m/s}^2 = 500\text{N}$

The maximum pressure is exerted when the block is resting on the smallest

surface, which is the minimum area. i.e.  $P_A = \frac{F}{A} = \frac{W}{A} = \frac{500\text{N}}{2\text{m}^2} = 250 \text{ N/m}^2$ . On

the contrary, when the surface area is maximum, the corresponding pressure will be minimum.

$$P = \frac{F}{A} = \frac{W}{A} \quad P = \frac{500\text{N}}{10\text{m}^2} \quad P = 50 \text{ N/m}^2$$

## Check point 3.1

1. What is pressure?
2. What are the dimensions of pressure? Discuss the units of pressure.
3. Explain how pressure varies with change of area.

## 3.2 Liquid Pressure

To understand the nature of pressure in liquids, you need to remember some common characteristics of liquids.

## Activity 3.3

*Discuss with your friends.*

1. The differences and similarities between solid and liquid in terms of: (shape, volume, weight, density, etc)
2. Consider a plastic bag containing water. If it is pierced in different sides, what will happen to the water? ( Fig 3.3)

In your discussion in Activity 3.3, you might have talked that:

- Liquids have no definite shape; they take the shape of their containers.
- Liquids have definite volume, mass and weight.
- Compared to molecules of solids, the molecules of liquids are relatively free to move. The densities of solids are greater than densities of liquids.

This and some other activities show that liquids exert pressure on the walls of the container in all direction. As shown in Fig 3.3 when a plastic bag filled with water is pierced, then water flows in all directions.



a) Plastic bag filled with water.

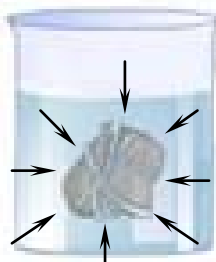

b) Water pressures is the same in all directions on the object submerged

Fig 3.3 Pressure in liquid acts in all directions

### Activity 3.4

Containers of different shapes and sizes are half filled with the same liquid. They will rise to the same level.

- What will be the pressure of the liquid at the bases of the containers?
- Is the pressure the same or different in different containers?
- Do the shapes of the containers affect the pressure?



Fig 3.4 Containers having different shapes filled with liquid to the same height.

Fig 3.5 illustrates the dependency of liquid pressure on height of the liquid in a container. The container has outlets 1, 2 and 3. The liquid coming out from outlet 3 travels longest distance while liquid coming from outlet 2 travels longer distance than outlet 1. This shows that the pressure at outlet 3

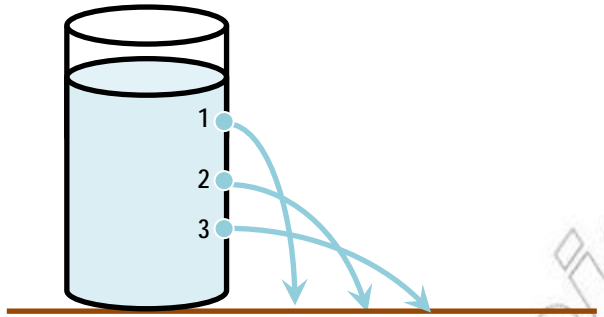

Fig.3.5 Pressure in liquids depends on the depth

is greater than pressures at 1 and 2. Activity 3.4 helps you to observe that, liquid pressure is independent of the shape of the container and the base area of the container.

This means, the liquid pressure depends only on the:-

- i) Depth ( $h$ ) from the top surface of the liquid,
- ii) Density of the liquid. The more denser the liquid the greater the pressure at any given depth.

Consider a liquid of density ( $\rho$ ) in a container. At a certain depth ( $h$ ), the force exerted by the liquid is equal to the weight of the liquid.

Thus the pressure,  $P = \frac{F}{A} = \frac{mg}{A}$ , where  $m$  is the mass.

But  $m = \rho V$ , by substituting the two equations, you get

$$P = \frac{F}{A} = \frac{mg}{A} = \frac{\rho Vg}{A},$$

Since the volume is the product of height and base area, ( $V = Ah$ ) then

$$\Rightarrow P = \frac{\rho Ahg}{A} \Rightarrow P = \rho gh$$

Consequently, the pressure exerted by a given liquid at a certain location is given by the equation  $P = \rho gh$ ;

Where  $p$  = pressure of liquid in  $N/m^2$

$\rho$  The density of liquid in  $kg/m^3$

$g$  = gravitational acceleration in  $m/s^2$

$h$  = depth of the liquid. (Height of the liquid above the point)

You can calculate the pressure exerted by water in a container, ocean, swimming pool, etc on an object, at any point (depth) of the water, using the equation of pressure, ( $P = \rho gh$ ).

### Activity 3.5

Neglecting air pressure: find the pressure at a depth of 10m, 100m, 1000 m and at the bottom of the ocean (2000 m.) Consider density of ocean water  $1030\text{kg/m}^3$  and  $g = 10\text{m/s}^2$ .

Properties of pressure in a liquid at rest:

1. Pressure exists at every point within the liquid.
2. The pressure is the same at all points at the same level within a single liquid.
3. The pressure is directly proportional to the height (depth below the surface) and density of the liquid ( $\rho$ )
4. The force on the bottom of a container is the pressure at that level times the area of the bottom. ( $F = PA$ ). This principle is used in the constructing of water dams.

### Examples 3.2

1. A certain container is filled with water of density  $1000\text{kg/m}^3$  to a height of 50cm. How much pressure is exerted on the base of the container? (take  $g = 10\text{m/s}^2$ ).

| Given   | Required | Solution   |
|---|----------|--|
| $\rho = 1000\text{kg/m}^3$<br>$h = 50\text{cm} = 0.5\text{m}$<br>$g = 10\text{m/s}^2$ | $p = ?$  | $P = \rho gh$<br>$P = 1000\text{kg/m}^3 \times 0.5\text{m} \times 10\text{m/s}^2$<br>$= 5000\text{N/m}^2$<br>$= 5000\text{Pa}$ |



2. Water is poured into a vessel up to a height of 2m. (Calculate the pressure of water on the base of the vessel. (Take  $g = 10\text{m/s}^2$ , density of water  $\rho_w = 1000\text{kg/m}^3$ ).

| Given  | Required | Solution   |
|--|----------|--|
| $h = 2\text{m},$<br>$g = 10\text{m/s}^2$<br>$\rho_w = 1000\text{kg/m}^3$ | $P = ?$  | $P = \rho gh = 1000\text{kg/m}^3 \times 10\text{m/s}^2 \times 2\text{m}$<br>$= 2 \times 10^4\text{N/m}^2$<br>$= 2 \times 10^4 p_a$ |

### Check point 3.2

1. Describe the Factors that affect liquid pressure.
2. Explain how liquid pressure varies with depth.

## 3.3 Pascal's Principle

### Activity 3.6

Can pressure be transmitted through a fluid? How?

A liquid can transmit any external pressure applied to it to all its parts. This property of liquid pressure is used in the hydraulic press, hydraulic brakes, to produce a large force from a small force.

A hydraulic press is consisted of a narrow cylinder connected to a wide cylinder both containing liquid (e.g. oil), and fitted with pistons A and B (as shown in Fig.3.6).

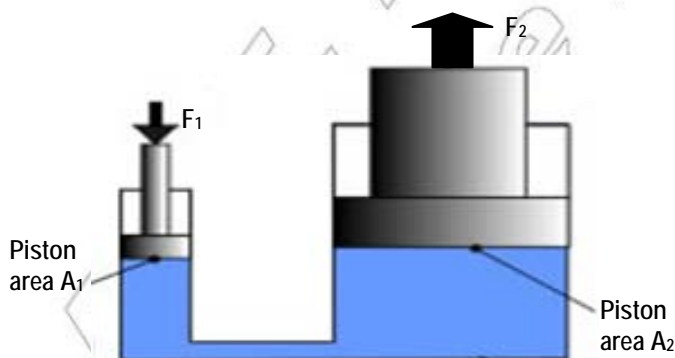

Fig 3.6 A- hydraulic press

### Challenging question

Can you mention some other applications of hydraulic press principles?

Liquids and gases can flow and are called fluids. If an external pressure is applied to a confined fluid, the pressure will be transmitted to every point in the fluid. This principle is known as Pascal's principle.

*Pascal's principle states that "a pressure applied to an enclosed fluid is transmitted undiminished to every portion of the fluid."*

Apply a force  $F_1$  on the smaller piston of cross sectional area  $A_1$ , directly on the liquid such as oil. Then the pressure is  $P_1 = \frac{F_1}{A_1}$ . This pressure is transmitted undiminished through the oil to the larger cylinder, which has area of  $A_2$ . Since the pressure must be the same on both sides;

$P_1 = P_2$  where  $P_2 = \frac{F_2}{A_2}$ . The force exerted on piston  $A_2$  is  $P_2 A_2 = F_2$ . The force  $F_2$  is much greater than  $F_1$ . Thus, Pascal's principle is expressed mathematically as

$$\begin{aligned}
 P_1 &= P_2 \\
 \Rightarrow \frac{F_1}{A_1} &= \frac{F_2}{A_2} \\
 \text{or } F_2 &= \frac{A_2}{A_1} \times F_1
 \end{aligned}$$

Pascal's principle is applied in technological devices which are used to produce great forces as in the case of hydraulic-press and brakes.

Consider Fig 3.6, which illustrates the working principle of a hydraulic press.

#### Examples 3.3

1. In a hydraulic press the small piston has an area of  $8 \text{ cm}^2$  while the large piston has an area of  $400 \text{ cm}^2$ . If a force of  $20 \text{ N}$  is applied on the small piston, what is the force on the larger piston?

| Given  | Required  | Solution  |
|--|-----------|---|
| $A_1 = 8\text{cm}^2$<br>$= 0.0008\text{m}^2$<br>$A_2 = 400\text{cm}^2$<br>$= 0.04\text{m}^2$<br>$F_1 = 20\text{N}$ | $F_2 = ?$ | $\frac{F_1}{A_1} = \frac{F_2}{A_2} \Rightarrow F_2 = \frac{A_2 \times F_1}{A_1}$ $= \frac{0.04\text{m}^2 \times 20\text{N}}{0.0008\text{m}^2}$ $= 1000\text{N}$ |

2. What should be the area of the large piston of a hydraulic press, if it is to lift a load of 20,000N when a force of 200N is applied on the small piston of area 1cm<sup>2</sup>?

| Given   | Required  | Solution  |
|---|-----------|---|
| $F_1 = 200\text{N}$<br>$F_2 = 20,000\text{N}$<br>$A_1 = 1\text{cm}^2$ | $A_2 = ?$ | $\frac{F_1}{A_1} = \frac{F_2}{A_2}$ $\Rightarrow A_2 = \frac{F_2}{F_1} \times A_1$ $= \frac{20,000\text{N}}{200\text{N}} \times 1$ $= 100\text{cm}^2$ |

3. In a hydraulic press the small piston has an area of 6cm<sup>2</sup> while the large piston has an area of 300 cm<sup>2</sup>. If a force of 30N is applied on the small piston, what load can it lift up (support)?

| Given  | Required  | Solution  |
|--|-----------|---|
| $A_1 = 6\text{cm}^2$<br>$A_2 = 300\text{cm}^2$<br>$F_1 = 30\text{N}$ | $F_2 = ?$ | $\frac{F_1}{A_1} = \frac{F_2}{A_2}$ $\Rightarrow F_2 = \frac{F_1}{A_1} \times A_2$ $= \frac{30\text{N}}{6\text{cm}^2} \times 300\text{cm}^2$ $= 1500\text{N}$ |

### Check point 3.3

1. State Pascal's principle.
2. Draw a hydraulic press diagram and describe how it functions.

### 3.4 Atmospheric Pressure-Air Pressure

The earth is surrounded by a huge mass of air called the **Atmosphere**.

The force of gravity acts on air. Fig 3.7 illustrates that inflated balloon weighs more than empty balloon. Thus, air has a weight. The weight of atmosphere exerts pressure on bodies found on the earth's surface. This pressure is called **Atmospheric pressure**.

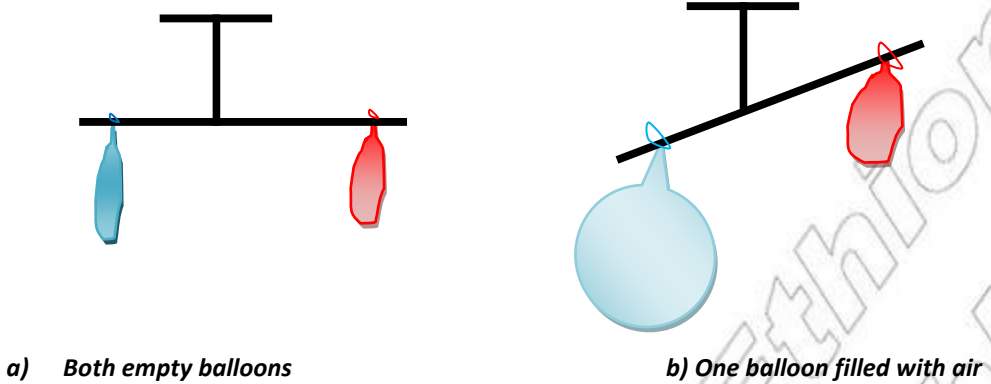

Fig 3.7 Air has a weight

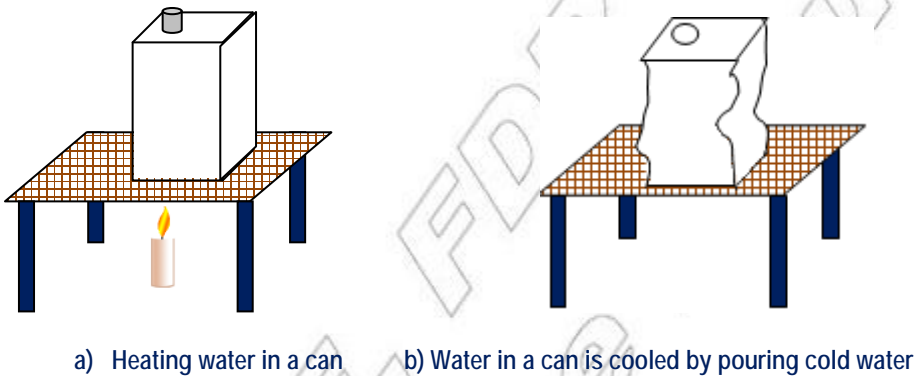

Fig 3.8. Crushing can experiment

**Activity 3.7 Crushing can experiment**

To observe the effect of atmospheric pressure. (Fig 3.8)

*Materials required:* Metal can, air tight stopper (cork), and small quantity of water, heat source (candle or Bunsen burner).

*Procedure*

1. Pour a small quantity of water in the can and boil it for a few minutes until steam is driven out.
2. Fit the cork tightly and remove the heat source away.
3. Pour cold water over the can so that the steam inside partly condenses into water and water vapor at low pressure.

*Write a short report about your observation by answering the following questions;*

1. What crushed the can?
2. What was the function of the heat and the steam inside the can?
3. What changed: mass, volume, density, temperature? Which quantity increased? decreased? Or remained the same?

From Activity 3.7 you see that, the can gets crushed inwards as in Fig.3-8 (b). This is due to the atmospheric pressure.

**Activity 3.8 The U-tube experiment**

*Materials required:* U-tube that contains water, rubber tube.

*Procedure:*

1. Pour water into the U-tube and mark the level.
2. By connecting the rubber tube with the U-tube, blow air into it and mark the level of water you raised.
  - i. What do you observe about the level of water in the two steps?
  - ii. Are the marks in the same level? Ask your friend to do the same and record the level of water raised.
  - iii. Explain what causes the level difference.

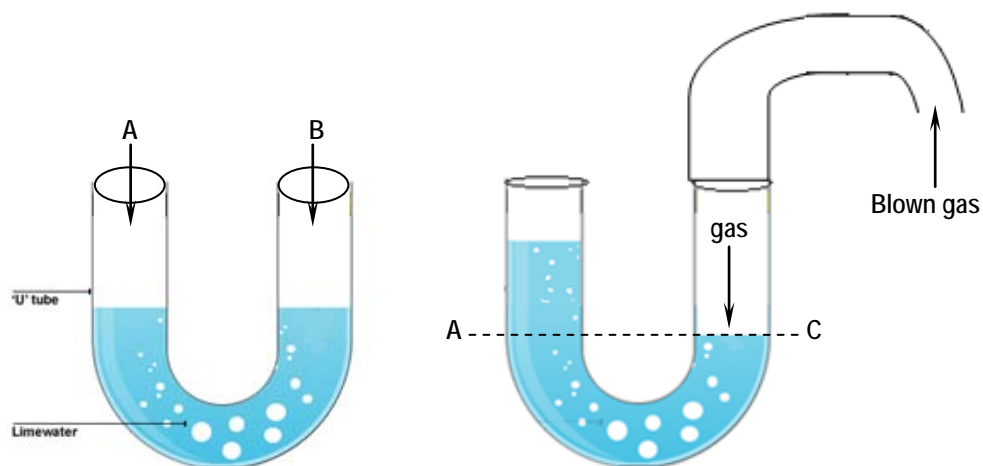

a) Equal pressure keeps the water level equal.

b) Extra pressure supports a column of liquid.

Fig 3.9. The U-tube experiment

In Activity 3.8 the water levels were the same before you blow air into the U-tube (Fig.3-9(a)). This is because; the same atmospheric pressure was exerted on sides A and B. But when air is gently blown into one of the tubes, say tube B, the level of water changes on the other side until the pressure at C becomes equal to the blown air pressure. Thus the blown air pressure supports a column of liquid in the other tube.

### Challenging question

Explain why water comes to your mouth when you suck water in a glass using drinking straw?

Air pressure varies from place to place. If we travel up a mountain or go up in a hot air balloon, for example, the air pressure gets lesser and lesser as we go higher and higher.

Each layer of air above the earth presses down on the layers below, and so the greatest pressure is at the ground level, where we have the maximum amount of air above.

Atmospheric pressure is the force per unit area exerted on a surface by the weight of the atmosphere above that surface. It is caused by the weight of atmosphere above the measurement point. Low pressure areas have less atmospheric mass above their location, whereas high pressure areas have more atmospheric mass above their location. Similarly, as elevation increases there is less overlying atmospheric mass, so that pressure decreases from sea level to the top of the atmosphere.

### Challenging question

Explain how liquids are drawn into a syringe tube when the plunger is pulled out.

If we go up into the sky and reach the outer layer of the atmosphere called the stratosphere, the pressure will decrease until it reaches about zero. At this height there is hardly any air above it.

### Check point 3.4

1. Does the air around us exert pressure? Explain and give examples
2. What is atmospheric pressure?
3. What is the main purpose of doing "crushing can experiment?"
4. Explain how atmospheric pressure varies with the change of altitudes.

## 3.5 Measuring Atmospheric Pressure

So far, you learnt the existence of atmospheric pressure. The next step is to ask how much strong this pressure is. To know the strength of atmospheric pressure, we need to measure it.

Atmospheric pressure is measured using an instrument called barometer. There are different kinds of barometers, but here we discuss only the mercury barometer.

Manometer is an instrument used to measure air pressure.

### Challenging question

Explain the difference between air pressure and atmospheric pressure.

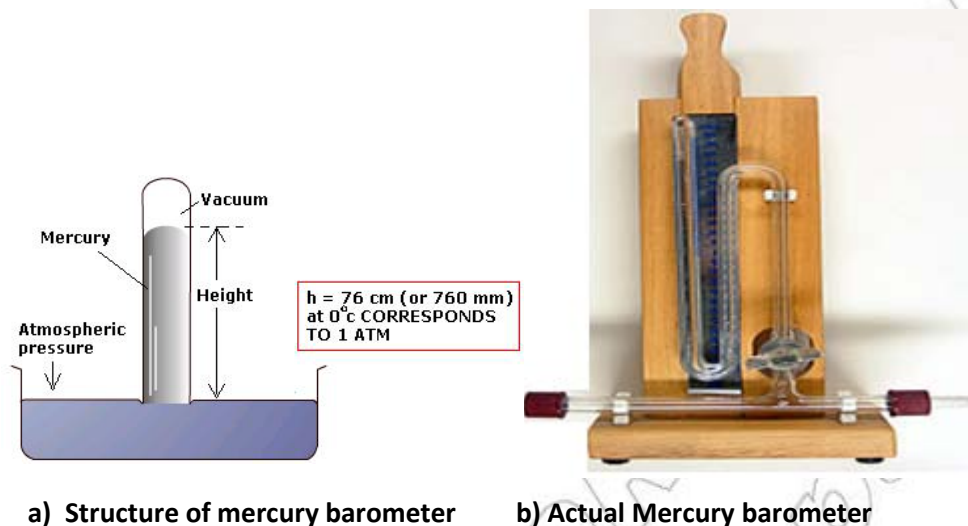

a) Structure of mercury barometer

b) Actual Mercury barometer

Fig. 3.10 The mercury barometer

**Mercury Barometer:** A glass tube about 80 cm long is completely filled with clean dry mercury. It is then inverted in a basin of mercury under the surface of mercury (Fig. 3.10(a)). The level of mercury in the tube falls leaving an empty space (vacuum) at the top. This apparatus is called the mercury barometer.

The column of mercury in the tube is supported by the atmospheric pressure,  $P_A$  acting on the surface of the mercury in the open dish. The exact height of the mercury column depends on the pressure of the atmosphere. Therefore, atmospheric pressure is measured by the height of mercury it supports.



The atmospheric pressure at sea level supports 76 cm of mercury. This means that atmospheric pressure equals the pressure at the bottom of a column of mercury 76 cm high or 760 mm of mercury.

Sometimes atmospheric pressure is expressed in torrs, Where: 1 torr =1mm of Mercury (Hg)

To find the value of atmospheric pressure in the SI unit, we use  $p = \rho gh$  where  $g = 10\text{m/s}^2$ ,  $\rho = 1.36 \times 10^4 \text{kg/m}^3$ , (the density of mercury) and  $h = 0.76 \text{m}$ ,

Thus 76 cm of Hg equals  $1 \times 10^5 \text{N/m}^2 = 1 \times 10^5 \text{p}_a$ .

**Standard atmospheric pressure** is taken to support a 760 mm high column of mercury at sea-level. That standard pressure is defined as the pressure at the foot of a column of mercury 760 mm high, equal to  $1.01 \times 10^5 \text{p}_a = 1 \text{atmosphere}$ . Another unit of pressure used in weather is the millibar (mb).  $1\text{mb} = 100\text{p}_a$ .

#### Relationships between different units of atmospheric pressure

1 millibar = 100pa

1 bar = 100,000 pa

1 torr = 1mm of Hg  
= 0.1 cm of Hg

1.01 bar = 1010 millibars

= 760 torrs

= 101,000 pa and it is known as SAP.

#### Activity 3.9

1. Explain why people don't use water barometer instead of mercury barometers?
2. Mention at least 3- disadvantages of using water in a barometer.
3. What are the major advantages of using mercury in a barometer?

Suppose we use a water barometer at sea level where atmospheric pressure is 76 cm of Hg. This means the atmosphere supports 76 cm of a column of mercury. Now let us calculate the height ( $h_w$ ) of the water barometer that the atmosphere can support.

Let  $h_m$  and  $h_w$  be heights of mercury and water supported by the atmospheric pressure respectively (see Fig 3.11 a and b).

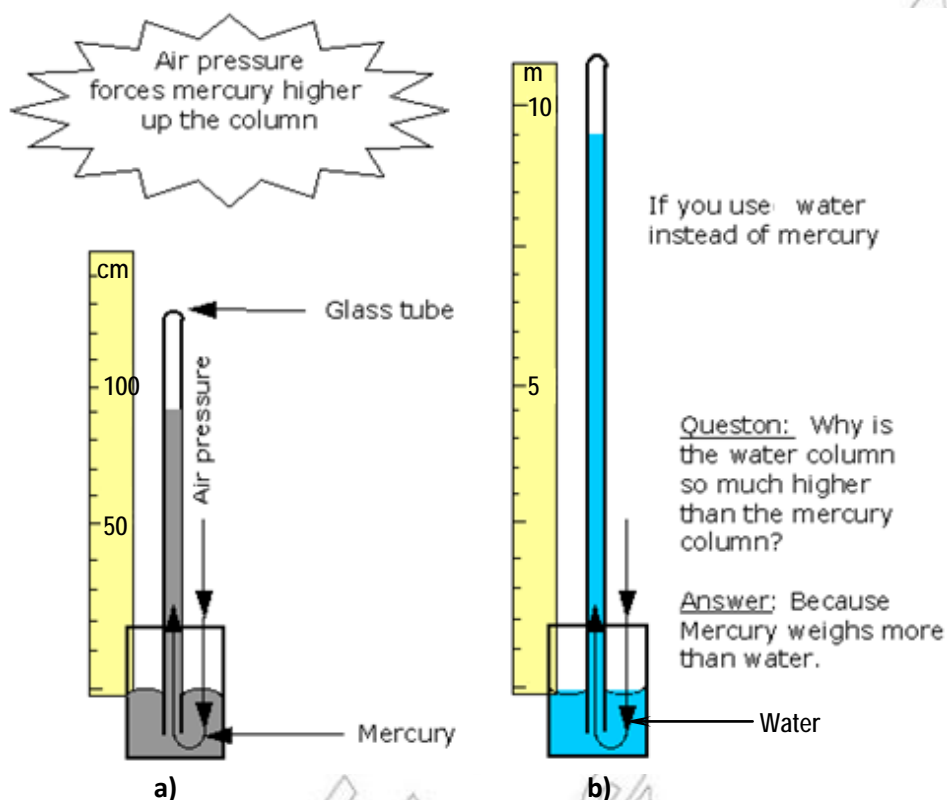

Fig 3.11. Comparison of mercury and water barometer

The atmosphere exerts the same pressure on the two barometers as they are placed at the same location. Hence the necessary height of water which is equivalent to 76 cm of Hg is 1034 cm or 10.34 m. That is, the water column rises up to 10.34 m through the tube. This means using water in a barometer requires

### 3 Pressure

us to have a tube taller than 10 m. Mercury barometers are small in size as the mercury rises only up to 76 cm.

Generally, mercury is selected for constructing a barometer due to the following advantages:

1. It is dense and therefore only a relatively short column of it is needed.
2. It is easy to see.
3. It doesn't freeze in very cold weather.
4. Very little is lost by evaporation.

#### Examples 3.4

1. What is the pressure in torr of a region whose atmospheric pressure is 64 cm-Hg?

| Given                   | Required                   | Solution  |
|-------------------------|----------------------------|---|
| $P = 64 \text{ cm -Hg}$ | $P \text{ in 'torr' } = ?$ | Since $1 \text{ cm} = 10 \text{ mm}$ , then<br>$P = 64 \text{ cm Hg} = 640 \text{ mm-Hg}$ .<br>But $1 \text{ mm Hg} = 1 \text{ torr}$ , hence<br>$640 \text{ mm-Hg} = 640 \text{ torr}$ |

2. In a certain area the atmospheric pressure is 820 torr. Express this pressure in Pascal, bar and millibar.

| Given                                    | Required   |
|--|--|
| $P \text{ (in torr)} = 820 \text{ torr}$ | i) $P \text{ (in Pascal)} = ?$<br>ii) $P \text{ (in bar)} = ?$<br>iii) $P \text{ (in millibar)} = ?$ |

#### Solution

- |  |  |  |
|--|--|--|
| i) $760 \text{ torr} = 101,000 \text{ pa}$<br>$820 \text{ torr} = ?$<br>$\Rightarrow P \text{ (in pa)} =$<br>$\frac{101,000 \text{ Pa} \times 820 \text{ torr}}{760 \text{ torr}}$ $108,933.68 \text{ Pa} =$ | ii) If $760 \text{ torr} = 1.01 \text{ bars}$<br>then $820 \text{ torr} = ?$<br>$\Rightarrow P \text{ (in bar)}$<br>$= \frac{1.01 \text{ bar} \times 820 \text{ torr}}{760 \text{ torr}}$ $= 1.08 \text{ bar}$ | iii) Since $1 \text{ bar}$<br>$= 1000 \text{ millibar}$<br>$\Rightarrow P \text{ (in millibar)} =$<br>$1.08 \times 1000 \text{ millibar}$<br>$= 1080 \text{ millibar}$ |
|--|--|--|

**Check point 3.5**

1. Explain how atmospheric pressure is measured in terms of the columns of liquids it supports.
2. Discuss the units of atmospheric pressure.
3. What is a barometric reading for standard atmospheric pressure?

**3.6 Applications of Atmospheric Pressure**

There are many different devices that operate by the application of atmospheric pressure. Siphons, lift pumps, syringes and rubber-suckers are some technological gadgets that apply the atmospheric pressure.

**1. Siphon**

A siphon is one of the applications of the knowledge of atmospheric pressure.

A siphon is a device that transfers a liquid from a higher level to a lower level without disturbing the whole liquid or displacing the vessels.

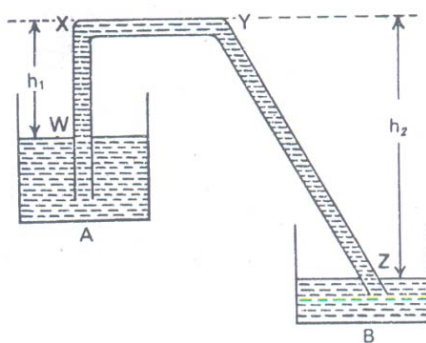

a)



b)

Fig 3.12 Siphons

"Siphon" is a tube or pipe which allows water (or another liquid) to flow from a high place, over a higher point and then down to a lower level. Siphons are

capable of raising water over a barrier. This is what makes them distinctive and interesting, as well as highly useful. A siphon is used in farm lands to move water from a reservoir to lower places.

It is also used to draw petroleum from a car tanker to a jerry can placed outside of a car. Try to observe such usages of siphon in your locality.

### Challenging questions

#### *Siphon experiment.*

1. If we connect two containers with different amounts of water by a siphon, what will the result be, after a very long time? Suck the water with your mouth from one end.
2. What will happen if you raise one end of the tube too high?

### Working conditions of a siphon

- i) A siphon cannot work in vacuum.
- ii) The siphon tube must be filled with a liquid.
- iii) The vertical height  $h_1$  of the top most point  $x$  of the shorter limb from the liquid level of the vessel A must be less than the barometric height of the liquid. (Fig 3.12a)
- iv) The liquid level of the vessel from which the liquid is transferred must be higher than that of the other.
- v) If there is an opening in the longer limb  $yz$  (Fig. 3.12(a)) below the level of the liquid in A, the siphon will work although the flow of the liquid will be slow.

### 2. Lift pump

A lift pump is a widely used device in different regions of our country. You might have observed it in the television set, when the rural people of Ethiopia are using it to pump water from deep well. It is very useful to our community as shown in Fig 3.13.

A lift pump has two valves, one on the piston and the other at the bottom of the barrel.

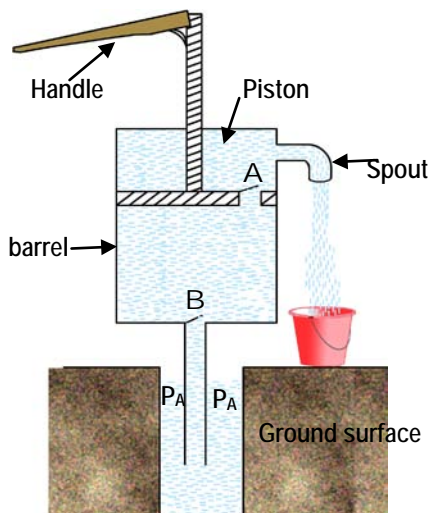

a) Structure of lift pump



b) The lift pump in action

Fig 3.13 Lift pump

To start the pump working, move the handle downwards so that valve 'B' closes and water inside the pump passes upward through valve A. When the handle moves up, valve A is closed and valve B is opened and water is pushed up the pipe through the valve 'B' by the atmospheric pressure. As the handle moves up and down continuously the atmospheric pressure pushes out the water through the spout.

### Activity 3.10 Project work: Constructing a lift pump

*Material required:* bamboo tubes, pail of water, and threads

*Procedures.*

- i. Visit a local water supply station that works with a lift pump.
- ii. Study the structure of this pump and how it operates.
- iii. Construct your own lift pump using the indicated material.
- iv. Explain how a lift pump is useful for a community.

### 3. The syringe

You are all familiar with a syringe from your early childhood. You used to play with it.

A syringe is used by doctors and nurses to give injection. It consists of a tightly fitted piston in a barrel.

The barrel will be filled by putting the nozzle under the liquid and drawing back the piston. This reduces the air pressure in the barrel and atmospheric pressure forces the liquid up into it. Pushing down the piston drives the liquid out of the nozzle. You can check how a syringe works by yourself.



Fig 3.14 The syringes

### 4. The rubber sucker

A simple and a very useful application of atmospheric pressure is found in a circular shallow rubber-cup known as **sucker**. Rubber suckers are used for attaching pictures on shops and car windows (Fig 3.15a). You might have observed these suckers in the windows of a taxi where picture are hung when you come to school. When the sucker is moisture to obtain a good air seal and pressed on a smooth flat surface, the cup is flattened and air is squeeze out from the sucker. Then atmospheric pressure holds the sucker firmly on to the surface.

Atmospheric pressure

Very low pressure

Rubber worker used for hanging thing

Alright seal, works best smooth surfaces. Improved by great or moisture

a)



b)

Fig 3.15. The Rubber sucker

Rubber suckers are also used in kitchen sinks to get rid of materials that block the flow of water. (Fig 3.15 b)

### 5. Drinking straw

Drinking straw shown in Fig 3.16 works with the help of atmospheric pressure. When you suck the air in the straw into your mouth you create a vacuum in it. The atmospheric pressure on the surface of the juice in the glass forces the juice to flow into the straws. As you continue to suck the air, the juice reaches your mouth.



Fig 3.16. Drinking straw

#### Check point 3.6

1. Mention some practical applications of atmospheric pressure.
2. Explain how siphons, pumps, syringes, rubber suckers function.



## SUMMARY

*In this unit you learnt that:*

- pressure is force per unit area  $P=F/A$ . Its SI unit is  $N/m^2$  or Pascal Pa. One Pascal of pressure is a force of one Newton being exerted on an area of one square meter.  
i.e  $1 \text{ pa} = 1N/m^2$
- pressure in solids depends on the area where the force is being exerts. Pressure in liquid at rest acts in all directions. Pressure in liquids depends on the depth of the liquid and the density of the liquid. ( $P=\rho gh$ )
- Pascal's law states that "the pressure applied to a confined fluid is transmitted undiminished to every point of the fluid". Its application is the hydraulic press.

$$\text{i.e. } \frac{F_1}{A_1} = \frac{F_2}{A_2}$$

- the air surrounding us has weight and exerts pressure on the surface of the earth. This pressure is called atmospheric pressure. A barometer is a device used to measure atmospheric pressure. The standard atmospheric pressure is 76 cm of Hg (mercury) or  
 $760 \text{ mm Hg} = 1 \text{ atm}$ ; where  $1 \text{ atm} = 1.01 \times 10^5 \text{ pa}$
- atmospheric Pressure plays a very important role in devices called pumps, siphon and rubber suckers. They operate themselves by the decrease and increase of pressure produced within the fluid.

## Review Questions and Problems

*I. Fill in the blank spaces with appropriate word or phrase.*

1. The SI unit of pressure is \_\_\_\_\_ .
2. The two main factors affecting pressure in a liquid are \_\_\_ and \_\_\_.
3. The instrument used to measure atmospheric pressure is \_\_\_\_\_.
4. Standard atmospheric pressure is equal to \_\_\_\_\_ Pa or \_\_\_\_\_ cm of Hg.

*II. Short answer Questions*

1. What is a pressure?
2. On what factors do pressure depend?
3. What mathematical expression do you use to calculate the pressure due to liquid at a given depth? Explain each term.
4. Describe the working principle of a hydraulic press using Pascal's principle.
5. List some applications of atmospheric pressure.
6. Draw a lift pump diagram and explain how it operates.

*III. Solve the following problems*

1. A metal box of weigh 20 N rests on its 1 m by 0.6m side on floor. How much is the pressure exerted by the metal box on the floor? Take  $g = 10 \text{ m/s}^2$ .
2. A rectangular container of base 50 cm by 30 cm is filled with water to a depth of 5 cm. How much is the pressure exerted at the base?  
(Take  $\rho_w = 1000 \text{ kg/m}^3$  and  $g = 10 \text{ m/s}^2$ )
3. How much is the pressure exerted at a point where a ball- pointed – pen of area  $1\text{mm}^2$  is pushed against the paper with a force of 24 N?
4. Suppose a scientist was able to construct a barometer with a liquid being twice denser than mercury, then how high would the liquid raise at standard pressure?
5. A cylindrical container is filled with oil to a depth of 32 cm. if the pressure exerted at the base of the container is known to be 2560pa then, how much is the density of the oil?