

Unit

1







POLYNOMIAL FUNCTIONS ARE THE MOST WIDELY USED FUNCTIONS IN MATHEMATICS. THEY ARISE NATURALLY IN MANY APPLICATIONS. ESSENTIALLY, THE GRAPH OF A POLYNOMIAL FUNCTION HAS NO BREAKS AND GAPS. IT DESCRIBES SMOOTH CURVES AS SHOWN IN THE FIGURE ABOVE.

POLYNOMIAL FUNCTIONS

Unit Outcomes:

After completing this unit, you should be able to:

-  *define polynomial functions.*
-  *perform the four fundamental operations on polynomials.*
-  *apply theorems on polynomials to solve related problems.*
-  *determine the number of rational and irrational zeros of a polynomial.*
-  *sketch and analyse the graphs of polynomial functions.*

Main Contents

1.1 Introduction to polynomial functions

1.2 Theorems on polynomials

1.3 Zeros of polynomial functions

1.4 Graphs of polynomial functions

Key Terms

Summary

Review Exercises

INTRODUCTION

THERE IS AN EXTREMELY IMPORTANT FAMILY OF FUNCTIONS IN MATHEMATICS CALLED POLYNOMIAL FUNCTIONS.

STATED QUITE SIMPLY, POLYNOMIAL FUNCTIONS ARE FUNCTIONS OF ONE VARIABLE, CONSISTING OF THE SUM OF SEVERAL TERMS, EACH TERM IS A PRODUCT OF TWO FACTORS, BEING A REAL NUMBER COEFFICIENT AND THE SECOND BEING A NON-NEGATIVE INTEGER POWER.

IN THIS UNIT YOU WILL BE LOOKING AT THE DIFFERENT COMPONENTS OF POLYNOMIAL FUNCTIONS. THESE ARE THEOREMS ON POLYNOMIAL FUNCTIONS; ZEROS OF A POLYNOMIAL FUNCTION; GRAPHS OF POLYNOMIAL FUNCTIONS. BASICALLY THE GRAPH OF A POLYNOMIAL FUNCTION IS A SMOOTH AND CONTINUOUS CURVE. HOWEVER, YOU WILL BE GOING OVER HOW TO USE THE DEGREE (EVEN OR ODD) AND THE LEADING COEFFICIENT TO DETERMINE THE END BEHAVIOUR OF

1.1 INTRODUCTION TO POLYNOMIAL FUNCTIONS



OPENING PROBLEM

OBVIOUSLY, THE VOLUME OF WATER IN ANY DAM FLUCTUATES FROM SEASON TO SEASON. AN ENGINEER SUGGESTS THAT THE VOLUME OF THE WATER (IN GIGA LITRES) IN A CERTAIN DAM t -MONTHS (STARTING IN SEPTEMBER) IS DESCRIBED BY THE MODEL:

$$v(t) = 450 - 170t + 22t^2 - 0.6t^3$$

ELECTRIC POWER CORPORATION RULES THAT IF THE VOLUME FALLS BELOW 200 GIGA LITRES, A WATER WISE PROJECT, "IRRIGATION", IS PROHIBITED. DURING WHICH MONTHS, IF ANY, WAS IRRIGATION PROHIBITED IN THE LAST 12 MONTHS?

RECALL THAT A FUNCTION f IS A RELATION IN WHICH NO TWO ORDERED PAIRS HAVE THE SAME FIRST ELEMENT, WHICH MEANS THAT FOR ANY ELEMENT x IN THE DOMAIN, THERE IS A UNIQUE PAIR

(x, y) BELONGING TO THE FUNCTION f

IN UNIT 4 OF GRADE 10 MATHEMATICS, YOU HAVE DISCUSSED FUNCTIONS SUCH AS:

$$f(x) = \frac{2}{3}x + \frac{1}{2}, g(x) = 5 - 3x, h(x) = 8x \text{ AND } d(x) = -\sqrt{3}x + 2.7.$$

SUCH FUNCTIONS ARE **linear functions**

A FUNCTION f IS A **linear function**, IF IT CAN BE WRITTEN IN THE FORM

$$f(x) = ax + b, a \neq 0,$$

WHERE a AND b ARE REAL NUMBERS.

THE **domain** OF f IS THE SET OF ALL REAL NUMBERS AND **range** IS THE SET OF ALL REAL NUMBERS.

IF $a = 0$, THEN f IS CALLED A **constant function**. IN THIS CASE,

$$f(x) = b.$$

THIS FUNCTION HAS THE SET OF ALL REAL NUMBERS AS ITS **domain** AND $\{b\}$ AS ITS **range**. ALSO RECALL WHAT YOU STUDIED ABOUT **quadratic functions**. EACH OF THE FOLLOWING FUNCTIONS IS A QUADRATIC FUNCTION.

$$f(x) = x^2 + 7x - 12, \quad g(x) = 9 + \frac{1}{4}x^2, \quad h(x) = -x^2 + 5, \quad k(x) = x^2,$$

$$l(x) = 2(x - 1)^2 + 3, \quad m(x) = (x + 2)(1 - x)$$

IF a, b, c ARE REAL NUMBERS, THEN THE FUNCTION

$$f(x) = ax^2 + bx + c \text{ IS A **quadratic function** .}$$

SINCE THE EXPRESSION $ax^2 + bx + c$ REPRESENTS A REAL NUMBER FOR ANY REAL NUMBER x , THE **domain** OF A QUADRATIC FUNCTION IS THE SET OF ALL REAL NUMBERS. THE RANGE OF A QUADRATIC FUNCTION DEPENDS ON THE VALUES OF a, b AND c .

Exercise 1.1

1 IN EACH OF THE FOLLOWING CASES, CLASSIFY THE FUNCTION AS A CONSTANT, LINEAR OR NONE OF THESE:

A $f(x) = 1 - x^2$

B $h(x) = \sqrt{2x-1}$

C $h(x) = 3 + 2^x$

D $g(x) = 5 - \frac{4}{5}x$

E $f(x) = 2\sqrt{3}$

F $f(x) = \left(\frac{2}{3}\right)^{-1}$

G $h(x) = 1 - |x|$

H $f(x) = (1 - \sqrt{2}x)(1 + \sqrt{2}x)$

I $k(x) = \frac{3}{4}(12 + 8x)$

J $f(x) = 12x^{-1}$

K $l(x) = \frac{(x+1)(x-2)}{x-2}$

L $f(x) = x^4 - x + 1$

2 FOR WHAT VALUES OF a, b, c IS $f(x) = ax^2 + bx + c$ A CONSTANT, A LINEAR OR A QUADRATIC FUNCTION?

1.1.1 Definition of a Polynomial Function

CONSTANT, LINEAR AND QUADRATIC FUNCTIONS ARE ALL SPECIAL CASES OF A W
FUNCTIONS CALLED **polynomial functions**.

Definition 1.1

Let n be a non-negative integer and let $a_n, a_{n-1}, \dots, a_1, a_0$ be real numbers with $a_n \neq 0$. The function

$$p(x) = a_n x^n + a_{n-1} x^{n-1} + \dots + a_1 x + a_0$$

is called a **polynomial function in variable x of degree n** .

NOTE THAT IN THE DEFINITION OF A POLYNOMIAL FUNCTION

$$p(x) = a_n x^n + a_{n-1} x^{n-1} + \dots + a_1 x + a_0$$

- I $a_n, a_{n-1}, a_{n-2}, \dots, a_1, a_0$ ARE CALLED **coefficients** OF THE POLYNOMIAL FUNCTION (OR SIMPLY THE POLYNOMIAL).
- II THE NUMBER a_n IS CALLED THE **leading coefficient** OF THE POLYNOMIAL FUNCTION AND $a_n x^n$ IS THE **leading term**.
- III THE NUMBER a_0 IS CALLED THE **constant term** OF THE POLYNOMIAL.
- IV THE NUMBER n (THE EXPONENT OF THE HIGHEST POWER) IS CALLED THE **degree** OF THE POLYNOMIAL.

NOTE THAT THE DOMAIN OF A POLYNOMIAL FUNCTION IS

EXAMPLE 1 WHICH OF THE FOLLOWING ARE POLYNOMIAL FUNCTIONS? FOR THOSE WHICH ARE POLYNOMIALS, FIND THE DEGREE, LEADING COEFFICIENT, AND CONSTANT TERM

A $f(x) = \frac{2}{3}x^4 - 12x^2 + x + \frac{7}{8}$

B $f(x) = \frac{x}{x}$

C $g(x) = \sqrt{(x+1)^2}$

D $f(x) = 2x^{-4} + x^2 + 8x + 1$

E $k(x) = \frac{x^2+1}{x^2+1}$

F $g(x) = \frac{8}{5}x^{15}$

G $f(x) = (1 - \sqrt{2}x)(1 + \sqrt{2}x)$

H $k(y) = \frac{6}{y}$

SOLUTION:

A IT IS A POLYNOMIAL FUNCTION OF DEGREE 4 WITH LEADING COEFFICIENT $\frac{2}{3}$ AND CONSTANT TERM $\frac{7}{8}$

B IT IS NOT A POLYNOMIAL FUNCTION BECAUSE ITS DOMAIN IS NOT \mathbb{R}

- C** $g(x) = \sqrt{(x+1)^2} = |x+1|$, SO IT IS NOT A POLYNOMIAL FUNCTION BECAUSE IT CANNOT BE WRITTEN IN THE FORM $a_n x^n + \dots + a_1 x + a_0$
- D** IT IS NOT A POLYNOMIAL FUNCTION BECAUSE ONE OF ITS TERMS HAS A NEGATIVE EXPONENT.
- E** $k(x) = \frac{x^2+1}{x^2+1} = 1$, SO IT IS A POLYNOMIAL FUNCTION OF DEGREE 0 WITH LEADING COEFFICIENT 1 AND CONSTANT TERM 1.
- F** IT IS A POLYNOMIAL FUNCTION OF DEGREE 8 WITH LEADING COEFFICIENT 5 AND CONSTANT TERM 0.
- G** IT IS A POLYNOMIAL FUNCTION OF DEGREE 2 WITH LEADING COEFFICIENT 2 AND CONSTANT TERM 1.
- H** IT IS NOT A POLYNOMIAL FUNCTION BECAUSE ITS DOMAIN IS NOT \mathbb{R}

A POLYNOMIAL EXPRESSION IS AN EXPRESSION OF THE FORM

$$a_n x^n + a_{n-1} x^{n-1} + \dots + a_1 x + a_0$$

WHERE n IS A NON NEGATIVE INTEGER AND EACH INDIVIDUAL EXPRESSION MAKING UP THE POLYNOMIAL IS CALLED A **term**.

ACTIVITY 1.1



- 1** FOR THE POLYNOMIAL EXPRESSION $x^2 + 3 - 6x^4 + \frac{7}{8}x - x^3$,
 - A** WHAT IS THE DEGREE?
 - B** WHAT IS THE LEADING COEFFICIENT?
 - C** WHAT IS THE COEFFICIENT OF x^3 ?
 - D** WHAT IS THE CONSTANT TERM?
- 2** A MATCH BOX HAS LENGTH x CM AND HEIGHT 3 CM,
 - A** EXPRESS ITS SURFACE AREA AS A FUNCTION OF x
 - B** WHAT IS THE DEGREE AND THE CONSTANT TERM OBTAINED ABOVE?

WE CAN RESTATE THE DEFINITIONS OF **quadratic functions** USING THE TERMINOLOGY FOR POLYNOMIALS. LINEAR FUNCTIONS ARE POLYNOMIAL FUNCTIONS OF DEGREE 1. **constant functions** ARE POLYNOMIAL FUNCTIONS OF DEGREE 0. SIMILARLY, **functions** ARE POLYNOMIAL FUNCTIONS OF DEGREE 2. THE ZERO FUNCTION, CONSIDERED TO BE A POLYNOMIAL FUNCTION BUT IS NOT ASSIGNED A DEGREE AT THIS LEVEL. NOTE THAT IN EXPRESSING A POLYNOMIAL, WE USUALLY OMIT ALL TERMS WHICH APPEAR WITH COEFFICIENTS AND WRITE OTHERS IN DECREASING ORDER, OR INCREASING ORDER, OF THE

EXAMPLE 2 FOR THE POLYNOMIAL FUNCTION $p(x) = \frac{x^2 - 2x^5 + 8}{4} + \frac{7}{8}x - x^3$,

- A** WHAT IS ITS DEGREE? **B** FIND a_n, a_{n-1}, a_{n-2} AND a_0
C WHAT IS THE CONSTANT TERM? **D** WHAT IS THE COEFFICIENT OF

SOLUTION:
$$p(x) = \frac{x^2 - 2x^5 + 8}{4} + \frac{7}{8}x - x^3 = \frac{x^2}{4} - \frac{2}{4}x^5 + \frac{8}{4} + \frac{7}{8}x - x^3$$

$$= -\frac{1}{2}x^5 - x^3 + \frac{1}{4}x^2 + \frac{7}{8}x + 2$$

- A** THE DEGREE IS 5.
B $a_n = a_5 = -\frac{1}{2}, a_{n-1} = a_4 = 0, a_{n-2} = a_3 = -1$ AND $a_0 = \frac{1}{4}$.
C THE CONSTANT TERM IS 2.
D THE COEFFICIENTS OF x IS $\frac{7}{8}$.

ALTHOUGH THE **domain** OF A POLYNOMIAL FUNCTION IS THE SET OF ALL REAL NUMBER, WE MAY HAVE TO SET A RESTRICTION ON THE DOMAIN BECAUSE OF OTHER CIRCUMSTANCES. FOR A GEOMETRICAL APPLICATION, IF A RECTANGLE HAS LENGTH x AND THE AREA OF THE RECTANGLE, THE DOMAIN OF THE FUNCTION p IS THE SET OF POSITIVE REAL NUMBERS. IN A POPULATION FUNCTION, THE DOMAIN IS THE SET OF POSITIVE INTEGERS.

Based on the types of coefficients it has, a polynomial function p is said to be:

- ✓ A POLYNOMIAL FUNCTION **over integers**, IF THE COEFFICIENTS ARE ALL INTEGERS.
- ✓ A POLYNOMIAL FUNCTION **over rational numbers**, IF THE COEFFICIENTS ARE ALL RATIONAL NUMBERS.
- ✓ A POLYNOMIAL FUNCTION **over real numbers**, IF THE COEFFICIENTS ARE ALL REAL NUMBERS.

Remark: EVERY POLYNOMIAL FUNCTION THAT WE WILL CONSIDER IN THIS UNIT IS A POLYNOMIAL FUNCTION OVER THE REAL NUMBERS.

FOR EXAMPLE, $f(x) = \frac{2}{3}x^4 - 13x^2 + \frac{7}{8}$, THEN IS A POLYNOMIAL FUNCTION OVER RATIONAL AND REAL NUMBERS, BUT NOT OVER INTEGERS.

IF $p(x)$ CAN BE WRITTEN IN THE FORM $a_n x^n + a_{n-1} x^{n-1} + \dots + a_1 x + a_0$ THEN DIFFERENT EXPRESSIONS CAN DEFINE THE SAME POLYNOMIAL FUNCTION.

FOR EXAMPLE, THE FOLLOWING EXPRESSIONS ALL DEFINE THE SAME POLYNOMIAL

$$\frac{1}{2}x^2 - x.$$

- A** $\frac{x^2 - 2x}{2}$ **B** $-x + \frac{1}{2}x^2$ **C** $\frac{1}{2}(x^2 - 2x)$ **D** $x\left(\frac{1}{2}x - 1\right)$

ANY EXPRESSION WHICH DEFINES A POLYNOMIAL FUNCTION IS CALLED A

EXAMPLE 3 FOR THE POLYNOMIAL EXPRESSION $x^5 - 1$,

- A** WHAT IS THE DEGREE? **B** WHAT IS THE COEFFICIENT OF
C WHAT IS THE LEADING COEFFICIENT? **D** WHAT IS THE CONSTANT TERM?

SOLUTION:

- A** THE DEGREE IS 5. **B** THE COEFFICIENT IS 1.
C THE LEADING COEFFICIENT IS 1. **D** THE CONSTANT TERM IS 1.

CONSIDER THE FUNCTIONS $f(x) = \frac{(x+3)(x-1)}{x-1}$ AND $g(x) = x + 3$.

WHEN $f(x)$ IS SIMPLIFIED IT GIVES $x + 3$, WHERE $x \neq 1$. AS THE DOMAIN IS NOT THE SET OF ALL REAL NUMBERS, $f(x)$ IS NOT A POLYNOMIAL FUNCTION. BUT $g(x)$ IS A POLYNOMIAL FUNCTION. THIS DEMONSTRATES THAT TWO FUNCTIONS CAN HAVE THE SAME ALGEBRAIC FORM BUT DIFFERENT DOMAINS. THE FUNCTIONS $f(x)$ AND $g(x)$ ARE NOT THE SAME FUNCTIONS.

WHEN YOU ARE TESTING AN EXPRESSION TO CHECK WHETHER OR NOT IT DEFINES A FUNCTION, YOU MUST BE CAREFUL AND WATCH THE **domain** OF THE FUNCTION DEFINED.

Exercise 1.2

- 1** WHICH OF THE FOLLOWING ARE POLYNOMIAL FUNCTIONS?
- A** $f(x) = 3x^4 - 2x^3 + x^2 + 7x - 9$ **B** $f(x) = x^{25} + 1$
C $f(x) = 3x^{-3} + 2x^{-2} + x + 4$ **D** $f(y) = \frac{1}{3}y^2 + \frac{2}{3}y + 1$
E $f(t) = \frac{3}{t} + \frac{2}{t^2}$ **F** $f(y) = 108 - 95y$
G $f(x) = 312x^6$ **H** $f(x) = \sqrt{3}x^2 - x^3 + \sqrt{2}$

I $f(x) = \sqrt{3x} + x + 3$

J $f(x) = \frac{4x^2 - 5x^3 + 6}{8}$

K $f(x) = \frac{3}{6+x}$

L $f(y) = \frac{18}{y}$

M $f(a) = \frac{a}{2a}$

N $f(x) = \frac{x}{12}$

O $f(x) = 0$

P $f(a) = a^{\frac{1}{2}} + 3a + a^2$

Q $f(x) = \frac{9}{17}x^{83} + \sqrt{54}x^{97} +$

R $f(t) = \frac{4}{7} - 2$

S $f(x) = (1-x)(x+2)$

T $g(x) = \left(x - \frac{2}{3}\right)\left(x + \frac{3}{4}\right)$

2 GIVE THE DEGREE, THE LEADING COEFFICIENT AND THE CONSTANT TERM OF EACH FUNCTION IN QUESTIONS ABOVE.

3 WHICH OF THE POLYNOMIAL FUNCTIONS ABOVE ARE:

- A** POLYNOMIAL FUNCTIONS OVER INTEGERS?
- B** POLYNOMIAL FUNCTIONS OVER RATIONAL NUMBERS?
- C** POLYNOMIAL FUNCTIONS OVER REAL NUMBERS?

4 WHICH OF THE FOLLOWING ARE POLYNOMIAL EXPRESSIONS?

- | | | |
|---------------------------------------|---------------------------------|-----------------------------------|
| A $2\sqrt{3} - x$ | B $y(y - 2)$ | C $\frac{(x+3)^2}{x+3}$ |
| D $\sqrt{y^2 + 3} + 2 - 3y^3$ | E $\frac{(y-3)(y-1)}{2}$ | F $\frac{(t-5)(t-1)}{t-1}$ |
| G $\frac{(x-3)(x^2+1)}{x^2+1}$ | H $y + 2y - 3y$ | I $\frac{x^2+4}{x^2+4}$ |

5 AN OPEN BOX IS TO BE MADE FROM A 20 CM LONG SQUARE PIECE OF MATERIAL, BY CUTTING EQUAL SQUARES OF LENGTH x CM FROM THE CORNERS AND TURNING UP THE SIDES AS SHOWN IN FIGURE 1.1

A VERIFY THAT THE VOLUME OF THE BOX IS GIVEN BY THE FUNCTION $V = x^3 - 80x^2 + 400x$.

B DETERMINE THE DOMAIN OF V

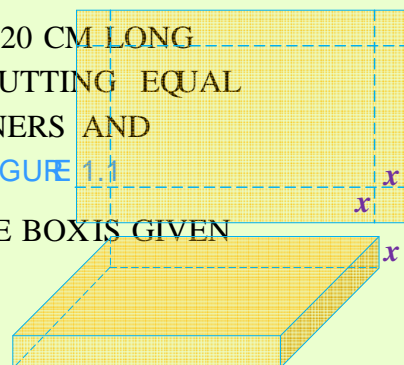

Figure 1.1

1.1.2 Operations on Polynomial Functions

RECALL THAT, IN ALGEBRA, THE FUNDAMENTAL OPERATIONS ARE ADDITION, MULTIPLICATION AND DIVISION. THE FIRST STEP IN PERFORMING OPERATIONS ON FUNCTIONS IS TO USE THE COMMUTATIVE, ASSOCIATIVE AND DISTRIBUTIVE LAWS COMBINE LIKE TERMS TOGETHER.

ACTIVITY 1.2



- 1 WHAT ARE LIKE TERMS? GIVE AN EXAMPLE.
- 2 ARE $8a^2$, $2a^3$ AND $6a$ LIKE TERMS? EXPLAIN.
- 3 FOR ANY THREE REAL NUMBERS, DETERMINE WHETHER EACH OF THE FOLLOWING STATEMENTS IS TRUE OR FALSE. GIVE REASONS FOR YOUR ANSWERS.

A $a - (b + c) = a - b + c$	B $a + (b - c) = a + b - c$
C $a - (b - c) = a - b + c$	D $a - (b - c) = a - b - c$
- 4 VERIFY EACH OF THE FOLLOWING STATEMENTS:

A $(4x + a) + (2a - x) = 3(a + x)$	B $5x^2y + 2xy^2 - (x^2y - xy^2) = 4x^2y + 3xy^2$
C $8a - (b + 9a) = -(a + b)$	D $2x - 4(x - y) + (y - x) = 5y - 3x$
- 5 IF $f(x) = x^3 - 2x^2 + 1$ AND $g(x) = x^2 - x - 1$, THEN WHICH OF THE FOLLOWING STATEMENTS ARE TRUE?

A $f(x) + g(x) = x^3 + x^2 - x$	B $f(x) - g(x) = x^3 - 3x^2 + x + 2$
C $g(x) - f(x) = 3x^2 + x^3 - x - 2$	D $f(x) - g(x) \neq g(x) - f(x)$.
- 6 IF f AND g ARE POLYNOMIAL FUNCTIONS OF DEGREE 3, THEN WHICH OF THE FOLLOWING STATEMENTS ARE NECESSARILY TRUE?

A $f + g$ IS OF DEGREE 3.	B $f + g$ IS OF DEGREE 6.
C $2f$ IS OF DEGREE 3.	D fg IS OF DEGREE 6.

Addition of polynomial functions

YOU CAN ADD POLYNOMIAL FUNCTIONS IN THE SAME WAY AS YOU ADD REAL NUMBERS. ADD THE LIKE TERMS BY ADDING THEIR COEFFICIENTS. NOTE THAT LIKE TERMS ARE THOSE WITH THE SAME VARIABLES TO THE SAME POWERS BUT POSSIBLY DIFFERENT COEFFICIENTS.

FOR EXAMPLE, IF $f(x) = 5x^4 - x^3 + 8x - 2$ AND $g(x) = 4x^3 - x^2 - 3x + 5$, THEN THE SUM OF $f(x)$ AND $g(x)$ IS THE POLYNOMIAL FUNCTION:

$$\begin{aligned} f(x) + g(x) &= (5x^4 - x^3 + 8x - 2) + (4x^3 - x^2 - 3x + 5) \\ &= 5x^4 + (-x^3 + 4x^3) - x^2 + (8x - 3x) + (-2 + 5) \dots \text{(grouping like terms)} \\ &= 5x^4 + (4 - 1)x^3 - x^2 + (8 - 3)x + (5 - 2) \dots \dots \dots \text{(adding their coefficients)} \\ &= 5x^4 + 3x^3 - x^2 + 5x + 3 \dots \dots \dots \text{(combining like terms)}. \end{aligned}$$

THEREFORE, THE SUM $f(x) + g(x) = 5x^4 + 3x^3 - x^2 + 5x + 3$ IS A POLYNOMIAL OF DEGREE 4.

THE SUM OF TWO POLYNOMIAL FUNCTIONS WRITTEN AS $f(x)$ AND $g(x)$ IS DEFINED AS:

$$f + g : (f + g)(x) = f(x) + g(x), \text{ FOR ALL } x \in \mathbb{R}.$$

EXAMPLE 4 IN EACH OF THE FOLLOWING, FIND THE SUM OF f AND g .

A $f(x) = x^3 + \frac{2}{3}x^2 - \frac{1}{2}x + 3$ AND $g(x) = -x^3 + \frac{1}{3}x^2 + x - 4$.

B $f(x) = 2x^5 + 3x^4 - 2\sqrt{2}x^3 + x - 5$ AND $g(x) = x^4 + \sqrt{2}x^3 + x^2 + 6x + 8$.

SOLUTION:

A
$$\begin{aligned} f(x) + g(x) &= (x^3 + \frac{2}{3}x^2 - \frac{1}{2}x + 3) + (-x^3 + \frac{1}{3}x^2 + x - 4) \\ &= (x^3 - x^3) + (\frac{2}{3}x^2 + \frac{1}{3}x^2) + (-\frac{1}{2}x + x) + (3 - 4) \dots \text{(grouping like terms)} \\ &= (1 - 1)x^3 + (\frac{2}{3} + \frac{1}{3})x^2 + (1 - \frac{1}{2})x + (3 - 4) \dots \text{(adding their coefficients)} \\ &= x^2 + \frac{1}{2}x - 1 \dots \dots \dots \text{(combining like terms)} \end{aligned}$$

SO, $f(x) + g(x) = x^2 + \frac{1}{2}x - 1$, WHICH IS A POLYNOMIAL OF DEGREE 2.

B
$$\begin{aligned} f(x) + g(x) &= (2x^5 + 3x^4 - 2\sqrt{2}x^3 + x - 5) + (x^4 + \sqrt{2}x^3 + x^2 + 6x + 8) \\ &= 2x^5 + (3x^4 + x^4) + (-2\sqrt{2}x^3 + \sqrt{2}x^3) + x^2 + (x + 6x) + (-5 + 8) \\ &= 2x^5 + (3 + 1)x^4 + (-2\sqrt{2} + \sqrt{2})x^3 + x^2 + (1 + 6)x + (8 - 5) \\ &= 2x^5 + 4x^4 - \sqrt{2}x^3 + x^2 + 7x + 3 \end{aligned}$$

SO, $f(x) + g(x) = 2x^5 + 4x^4 - \sqrt{2}x^3 + x^2 + 7x + 3$, WHICH IS A POLYNOMIAL FUNCTION OF DEGREE 5.

ACTIVITY 1.3



- 1 WHAT DO YOU OBSERVE IN EXAMPLE 4 ABOUT THE DEGREE OF $f(x)$ AND $g(x)$?
- 2 IS THE DEGREE OF $(f - g)(x)$ EQUAL TO THE DEGREE OF $f(x)$, WHICHEVER HAS THE HIGHEST DEGREE?
- 3 IF $f(x)$ AND $g(x)$ HAVE SAME DEGREE, THEN THE DEGREE OF $(f - g)(x)$ MIGHT BE LOWER THAN THE DEGREE OF $f(x)$ OR THE DEGREE OF $g(x)$. WHICH PART OF EXAMPLE 4 ILLUSTRATES THIS SITUATION? WHY DOES THIS HAPPEN?
- 4 WHAT IS THE DOMAIN OF $(f - g)(x)$?

Subtraction of polynomial functions

TO SUBTRACT A POLYNOMIAL FROM A POLYNOMIAL, SUBTRACT THE COEFFICIENTS OF THE CORRESPONDING LIKE TERMS. SO, WHICHEVER TERM IS TO BE SUBTRACTED, ITS SIGN IS CHANGED. THEN THE TERMS ARE ADDED.

FOR EXAMPLE, IF $f(x) = 2x^3 - 5x^2 + x - 7$ AND $g(x) = 8x^2 - x^3 + 4x + 5$, THEN THE DIFFERENCE OF $f(x)$ AND $g(x)$ IS THE POLYNOMIAL FUNCTION:

$$\begin{aligned} f(x) - g(x) &= (2x^3 - 5x^2 + x - 7) - (8x^2 - x^3 + 4x + 5) \\ &= 2x^3 - 5x^2 + x - 7 - 8x^2 + x^3 - 4x - 5 \dots\dots\dots (\text{removing brackets}) \\ &= (2 + 1)x^3 + (-5 - 8)x^2 + (1 - 4)x + (-7 - 5) \dots\dots\dots (\text{adding coefficients of like terms}) \\ &= 3x^3 - 13x^2 - 3x - 12 \dots\dots\dots (\text{combining like terms}) \end{aligned}$$

THE DIFFERENCE OF TWO POLYNOMIAL FUNCTIONS WRITTEN AS $f(x)$ AND $g(x)$ IS DEFINED AS:

$$(f - g) : (f - g)(x) = f(x) - g(x), \text{ FOR ALL } x \in \mathbb{R} .$$

EXAMPLE 5 IN EACH OF THE FOLLOWING, FIND $f - g$

A $f(x) = x^4 + 3x^3 - x^2 + 4$ AND $g(x) = x^4 - x^3 + 5x^2 + 6x$

B $f(x) = x^5 + 2x^3 - 8x + 1$ AND $g(x) = x^3 + 2x^2 + 6x - 9$

SOLUTION:

A
$$\begin{aligned} f(x) - g(x) &= (x^4 + 3x^3 - x^2 + 4) - (x^4 - x^3 + 5x^2 + 6x) \\ &= x^4 + 3x^3 - x^2 + 4 - x^4 + x^3 - 5x^2 - 6x \dots\dots\dots (\text{removing brackets}) \\ &= (1 - 1)x^4 + (3 + 1)x^3 + (-1 - 5)x^2 - 6x + 4 \dots\dots\dots (\text{adding their coefficients}) \\ &= 4x^3 - 6x^2 - 6x + 4 \dots\dots\dots (\text{combining like terms}) \end{aligned}$$

THEREFORE, THE DIFFERENCE IS A POLYNOMIAL FUNCTION OF DEGREE 3,

$$f(x) - g(x) = 4x^3 - 6x^2 - 6x + 4$$

$$\begin{aligned}
 \text{B } f(x) - g(x) &= (x^5 + 2x^3 - 8x + 1) - (x^3 + 2x^2 + 6x - 9) \\
 &= x^5 + 2x^3 - 8x + 1 - x^3 - 2x^2 - 6x + 9 \\
 &= x^5 + (2x^3 - x^3) - 2x^2 + (-8x - 6x) + (1 + 9) \\
 &= x^5 + (2 - 1)x^3 - 2x^2 + (-8 - 6)x + (1 + 9) \\
 &= x^5 + x^3 - 2x^2 - 14x + 10
 \end{aligned}$$

THEREFORE THE DIFFERENCE $(f - g)(x) = x^5 + x^3 - 2x^2 - 14x + 10$, WHICH IS A POLYNOMIAL FUNCTION OF DEGREE 5.

NOTE THAT IF THE DEGREE OF F IS NOT EQUAL TO THE DEGREE OF G, THEN THE DEGREE OF (F - G)(x) OR THE DEGREE OF (FG)(x) WHICHEVER HAS THE HIGHEST DEGREE. IF THEY HAVE THE SAME DEGREE, HOWEVER, THE DEGREE MIGHT BE LOWER THAN THIS COMMON DEGREE WHEN THEY HAVE THE SAME LEADING COEFFICIENT AS ILLUSTRATED IN

Multiplication of polynomial functions

TO MULTIPLY TWO POLYNOMIAL FUNCTIONS, MULTIPLY EACH TERM OF ONE BY EACH OTHER, AND COLLECT LIKE TERMS.

FOR EXAMPLE, $f(x) = 2x^3 - x^2 + 3x - 2$ AND $g(x) = x^2 - 2x + 3$. THEN THE PRODUCT OF $f(x)$ AND $g(x)$ IS A POLYNOMIAL FUNCTION:

$$\begin{aligned}
 f(x) \cdot g(x) &= (2x^3 - x^2 + 3x - 2) \cdot (x^2 - 2x + 3) \\
 &= 2x^3(x^2 - 2x + 3) - x^2(x^2 - 2x + 3) + 3x(x^2 - 2x + 3) - 2(x^2 - 2x + 3) \\
 &= 2x^5 - 4x^4 + 6x^3 - x^4 + 2x^3 - 3x^2 + 3x^3 - 6x^2 + 9x - 2x^2 + 4x - 6 \\
 &= 2x^5 + (-4x^4 - x^4) + (6x^3 + 2x^3 + 3x^3) + (-3x^2 - 6x^2 - 2x^2) + (9x + 4x) - 6 \\
 &= 2x^5 - 5x^4 + 11x^3 - 11x^2 + 13x - 6
 \end{aligned}$$

THE PRODUCT OF TWO POLYNOMIAL FUNCTIONS IS WRITTEN AS $f \cdot g$ AND IS DEFINED AS:

$$f \cdot g : (f \cdot g)(x) = f(x) \cdot g(x), \text{ FOR ALL } x \in \mathbb{R}.$$

EXAMPLE 6 IN EACH OF THE FOLLOWING, FIND THE DEGREE OF $f \cdot g$:

$$\text{A } f(x) = \frac{3}{4}x^2 + \frac{9}{2}, g(x) = 4x \quad \text{B } f(x) = x^2 + 2x, g(x) = x^5 + 4x^2 - 2$$

SOLUTION: A $f(x) \cdot g(x) = \left(\frac{3}{4}x^2 + \frac{9}{2}\right) \cdot (4x) = 3x^3 + 18x$

SO, THE PRODUCT $(f \cdot g)(x) = 3x^3 + 18x$ HAS DEGREE 3.

$$\begin{aligned}
 \text{B } f(x).g(x) &= (x^2 + 2x).(x^5 + 4x^2 - 2) \\
 &= x^2(x^5 + 4x^2 - 2) + 2x(x^5 + 4x^2 - 2) \\
 &= x^7 + 2x^6 + 4x^4 + 8x^3 - 2x^2 - 4x
 \end{aligned}$$

SO, THE PRODUCT $f(x).g(x) = x^7 + 2x^6 + 4x^4 + 8x^3 - 2x^2 - 4x$ HAS DEGREE 7.

IN EXAMPLE 6, YOU CAN SEE THAT THE DEGREE OF THE PRODUCT IS THE SUM OF THE DEGREES OF THE TWO POLYNOMIAL FUNCTIONS f AND g .

TO FIND THE PRODUCT OF TWO POLYNOMIAL FUNCTIONS, WE CAN ALSO USE A VERTICAL METHOD FOR MULTIPLICATION.

EXAMPLE 7 LET $f(x) = 3x^2 - 2x^3 + x^5 - 8x + 1$ AND $g(x) = 5 + 2x^2 + 8x$. FIND $f(x).g(x)$ AND THE DEGREE OF THE PRODUCT.

SOLUTION: TO FIND THE PRODUCT, FIRST REARRANGE EACH POLYNOMIAL IN DESCENDING POWERS AS FOLLOWS:

$$\begin{array}{r}
 x^5 - 2x^3 + 3x^2 - 8x + 1 \\
 \underline{2x^2 + 8x + 5} \\
 5x^5 + 0x^4 - 10x^3 + 15x^2 - 40x + 5 \dots\dots \text{(multiplying by 5)} \\
 8x^6 + 0x^5 - 16x^4 + 24x^3 - 64x^2 + 8x \dots\dots \text{(multiplying by 8x)} \\
 \underline{2x^7 + 0x^6 - 4x^5 + 6x^4 - 16x^3 + 2x^2} \dots\dots \text{(multiplying by } 2x^2\text{)} \\
 2x^7 + 8x^6 + x^5 - 10x^4 - 2x^3 - 47x^2 - 32x + 5 \dots\dots \text{(adding vertically.)}
 \end{array}$$

THUS $f(x).g(x) = 2x^7 + 8x^6 + x^5 - 10x^4 - 2x^3 - 47x^2 - 32x + 5$ AND HENCE THE DEGREE OF $f.g$ IS 7.

ACTIVITY 1.4



- 1 FOR ANY NON-ZERO POLYNOMIAL FUNCTION, IF THE DEGREE OF f IS m AND THE DEGREE OF g IS n , THEN WHAT IS THE DEGREE OF $f.g$?
- 2 IF EITHER OF f OR g IS THE ZERO POLYNOMIAL, WHAT IS THE DEGREE OF $f.g$?
- 3 IS THE PRODUCT OF TWO OR MORE POLYNOMIALS ALWAYS A POLYNOMIAL?

EXAMPLE 8 (Application of polynomial functions)

A PERSON WANTS TO MAKE AN OPEN BOX BY CUTTING EQUAL SQUARES FROM THE CORNERS OF A PIECE OF METAL 160 CM BY 240 CM AS SHOWN IN FIGURE 1.1. IF THE EDGE OF EACH CUT-OUT SQUARE IS x CM, FIND THE VOLUME OF THE BOX WHEN $x = 3$.

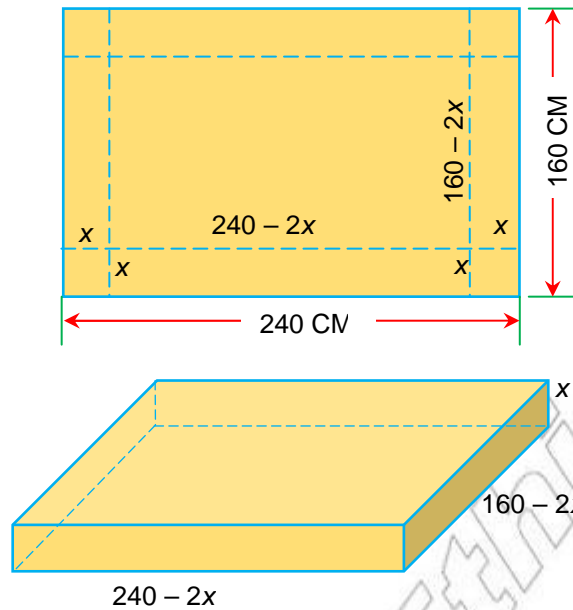

FIGURE 1.2

SOLUTION: THE VOLUME OF A RECTANGULAR BOX IS EQUAL TO THE PRODUCT OF ITS LENGTH AND WIDTH AND HEIGHT. FROM THE FIGURE, THE LENGTH IS $240 - 2x$, THE WIDTH IS $160 - 2x$, AND THE HEIGHT IS x . THE VOLUME OF THE BOX IS

$$\begin{aligned} v(x) &= (240 - 2x)(160 - 2x)(x) \\ &= (38400 - 800x + 4x^2)(x) \\ &= 38400x - 800x^2 + 4x^3 \text{ (A POLYNOMIAL OF DEGREE 3)} \end{aligned}$$

WHEN $x = 1$, THE VOLUME OF THE BOX IS $38400 - 800 + 4 = 37604 \text{ cm}^3$

WHEN $x = 3$, THE VOLUME OF THE BOX IS

$$v(3) = 38400(3) - 800(3)^2 + 4(3)^3 = 115200 - 7200 + 108 = 108,108 \text{ cm}^3$$

Division of polynomial functions

IT IS POSSIBLE TO DIVIDE A POLYNOMIAL BY A POLYNOMIAL USING A PROCESSING DIVISION SIMILAR TO THAT USED IN ARITHMETIC.

LOOK AT THE CALCULATIONS BELOW, WHERE 939 IS BEING DIVIDED BY 12.

$$\begin{array}{r} 7 \\ 12 \overline{) 939} \\ \underline{84} \\ 99 \end{array}$$

$$\begin{array}{r} 78 \\ 12 \overline{) 939} \\ \underline{84} \\ 99 \\ \underline{96} \\ 3 \end{array}$$

THE SECOND DIVISION CAN BE EXPRESSED BY AN EQUATION WHICH SAYS NOTHING ABOUT

$$939 = (78 \times 12) + 3. \text{ OBSERVE THAT, } 939 \div 12 = 78 + (3 \div 12) \text{ OR } \frac{939}{12} = 78 + \frac{3}{12}.$$

HERE 939 IS THE DIVIDEND, 12 IS THE DIVISOR, 78 IS THE QUOTIENT AND 3 IS THE REMAINDER OF THE DIVISION. WHAT WE ACTUALLY DID IN THE ABOVE CALCULATION WAS TO CONTINUE AS LONG AS THE QUOTIENT AND THE REMAINDER ARE INTEGERS AND THE REMAINDER IS LESS THAN THE DIVISOR.

ACTIVITY 1.5

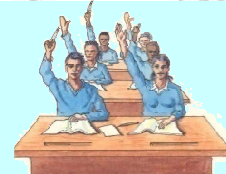

- 1 CONSIDER THE FOLLOWING: $\frac{x^2 - x + 2}{x - 2} = x + 1 + \frac{4}{x - 2}$. WHICH POLYNOMIALS DO YOU THINK WE SHOULD CALL THE DIVISOR, DIVIDEND, QUOTIENT AND REMAINDER?
- 2 DIVIDE $x^3 + 1$ BY $x + 1$. (YOU SHOULD SEE THAT THE REMAINDER IS 0)
- 3 WHEN DO WE SAY THE DIVISION IS EXACT?
- 4 WHAT MUST BE TRUE ABOUT THE DEGREES OF THE DIVIDEND AND THE DIVISOR BEFORE WE CAN TRY TO DIVIDE POLYNOMIALS?
- 5 SUPPOSE THE DEGREE OF THE DIVIDEND IS n AND IF THE DIVISOR IS m AND $n > m$, THEN WHAT WILL BE THE DEGREE OF THE QUOTIENT?

WHEN SHOULD WE STOP DIVIDING ONE POLYNOMIAL BY ANOTHER? LOOK AT THE CALCULATIONS BELOW:

$$\begin{array}{r}
 x \\
 \hline
 x+1 \overline{) x^2 + 3x + 5} \\
 \underline{x^2 + x} \\
 2x + 5
 \end{array}
 \qquad
 \begin{array}{r}
 x + 2 \\
 \hline
 x+1 \overline{) x^2 + 3x + 5} \\
 \underline{x^2 + x} \\
 2x + 5 \\
 \underline{2x + 2} \\
 3
 \end{array}
 \qquad
 \begin{array}{r}
 x + 2 + \frac{3}{x + 1} \\
 \hline
 x+1 \overline{) x^2 + 3x + 5} \\
 \underline{x^2 + x} \\
 2x + 5 \\
 \underline{2x + 2} \\
 3 \\
 \underline{3} \\
 0
 \end{array}$$

THE FIRST DIVISION ABOVE TELLS US THAT

$$x^2 + 3x + 5 = x(x + 1) + 2x + 5.$$

IT HOLDS TRUE FOR ALL VALUES OF x . IN THE MIDDLE ONE OF THE THREE DIVISIONS, YOU STOPPED AS LONG AS YOU GOT A QUOTIENT AND REMAINDER WHICH ARE BOTH POLYNOMIALS.

WHEN YOU ARE ASKED TO DIVIDE ONE POLYNOMIAL BY ANOTHER, STOP THE DIVISION WHEN YOU GET A QUOTIENT AND REMAINDER THAT ARE POLYNOMIALS AND THE DEGREE OF THE REMAINDER IS LESS THAN THE DEGREE OF THE DIVISOR.

STUDY THE EXAMPLE BELOW TO DIVIDE $2x^3 - 3x^2 + 4x + 7$ BY $x - 2$.

Think $\frac{x^2}{x} = x$

Think $\frac{2x^3}{x} = 2x^2$ *Think $\frac{6x}{x} = 6$*

$$\begin{array}{r}
 \text{Quotient} \quad 2x^2 + x + 6 \\
 \text{Divisor } \rightarrow x - 2 \overline{) 2x^3 - 3x^2 + 4x + 7} \\
 \underline{2x^3 - 4x^2} \\
 x^2 + 4x + 7 \\
 \underline{x^2 - 2x} \\
 6x + 7 \\
 \underline{6x - 12} \\
 19 \\
 \text{Remainder} \rightarrow 19
 \end{array}$$

← Dividend
← multiply $2x^2(x - 2)$
← subtract
← multiply $x(x - 2)$
← subtract
← multiply $6(x - 2)$
← subtract

SO, DIVIDING $2x^3 - 3x^2 + 4x + 7$ BY $x - 2$ GIVES A QUOTIENT OF $2x^2 + x + 6$ AND A REMAINDER OF 19. THAT IS, $\frac{2x^3 - 3x^2 + 4x + 7}{x - 2} = 2x^2 + x + 6 + \frac{19}{x - 2}$

THE QUOTIENT (DIVISION) OF TWO POLYNOMIAL FUNCTIONS WRITTEN AS $f(x)$ AND $g(x)$ IS DEFINED AS:

$$f \div g : (f \div g)(x) = f(x) \div g(x), \text{ PROVIDED THAT } g(x) \neq 0, \text{ FOR ALL } x \in \mathbb{R}.$$

EXAMPLE 9 DIVIDE $x^3 - 3x + 5$ BY $2x - 3$

SOLUTION:

$$\begin{array}{r}
 2x^2 + 3x + 3 \\
 2x - 3 \overline{) 4x^3 + 0x^2 - 3x + 5} \\
 \underline{4x^3 - 6x^2} \\
 6x^2 - 3x + 5 \\
 \underline{6x^2 - 9x} \\
 6x + 5 \\
 \underline{6x - 9} \\
 14 \\
 \text{REMAINDER} \rightarrow 14
 \end{array}$$

Arrange the dividend and the divisor in descending powers of x .

Insert (with 0 coefficients) for missing terms.

Divide the first term of the dividend by the first term of the divisor.

Multiply the divisor by $2x^2$, line up like terms and, subtract

Repeat the process until the degree of the remainder is less than that of the divisor.

THEREFORE, $x^3 - 3x + 5 = (2x^2 + 3x + 3)(2x - 3) + 14$

EXAMPLE 10 FIND THE QUOTIENT AND REMAINDER WHEN $x^5 + 4x^3 - 6x^2 - 8$ IS DIVIDED BY $3x + 2$.

SOLUTION:

$$\begin{array}{r}
 x^3 - 3x^2 + 11x - 33 \\
 \hline
 x^2 + 3x + 2 \overline{) x^5 + 0x^4 + 4x^3 - 6x^2 + 0x - 8} \\
 \underline{x^5 + 3x^4 + 2x^3} \\
 -3x^4 + 2x^3 - 6x^2 + 0x - 8 \\
 \underline{-3x^4 - 9x^3 - 6x^2} \\
 11x^3 + 0x^2 + 0x - 8 \\
 \underline{11x^3 + 33x^2 + 22x} \\
 -33x^2 - 22x - 8 \\
 \underline{-33x^2 - 99x - 66} \\
 77x + 58
 \end{array}$$

THEREFORE THE QUOTIENT IS $11x - 33$ AND THE REMAINDER IS $77x + 58$.

WE CAN WRITE THE RESULT AS $\frac{x^5 + 4x^3 - 6x^2 - 8}{x^2 + 3x + 2} = x^3 - 3x^2 + 11x - 33 + \frac{77x + 58}{x^2 + 3x + 2}$.

Group Work 1.1



- FIND TWO POLYNOMIAL FUNCTIONS OF DEGREE n WITH $h + g$ OF DEGREE ONE. WHAT RELATIONS DO THERE BE BETWEEN THE LEADING COEFFICIENTS OF h AND g ?
- GIVEN $f(x) = x + 2$ AND $g(x) = ax + b$, FIND ALL VALUES OF a AND b SO THAT $\frac{f}{g}$ IS A POLYNOMIAL FUNCTION.
- GIVEN POLYNOMIAL FUNCTIONS $p(x) = x^2 + 3$, $q(x) = x^2 - 5$ AND $r(x) = 2x + 1$, FIND A FUNCTION SUCH THAT $\frac{f(x)}{g(x)} = q(x) + \frac{r(x)}{g(x)}$.

Exercise 1.3

- WRITE EACH OF THE FOLLOWING EXPRESSIONS AS A POLYNOMIAL IN THE FORM

$$a_n x^n + a_{n-1} x^{n-1} + \dots + a_1 x + a_0$$

A $(x^2 - x - 6) - (x + 2)$ **B** $(x^2 - x - 6)(x + 2)$

C $(x + 2) - (x^2 - x - 6)$ **D** $\frac{x^2 - x - 6}{x + 2}$

E $\frac{x + 2}{x^2 - x - 6}$ **F** $(x^2 - x - 6)^2$

G $2^{x-3} + 2^3 - x$ **H** $(2x + 3)^2$

I $(x^2 - x + 1)(x^2 - 3x + 5)$ **J** $(x^3 - x^4 + 2x + 1) - (x^4 + x^3 - 2x^2 + 8)$

2 LET f AND g BE POLYNOMIAL FUNCTIONS SUCH THAT $g(x) = x^2 - x + 3$. WHICH OF THE FOLLOWING FUNCTIONS ARE ALSO POLYNOMIAL FUNCTIONS?

A $f + g$ **B** $g - f$ **C** $f \cdot g$ **D** $\frac{f}{g}$

E $f^2 - g$ **F** $2f + 3g$ **G** $\sqrt{f^2}$

3 IF f AND g ARE ANY TWO POLYNOMIAL FUNCTIONS, WHICH OF THE FOLLOWING WILL A POLYNOMIAL FUNCTION?

A $f + g$ **B** $f - g$ **C** $f \cdot g$ **D** $\frac{f}{g}$

E f^2 **F** $\frac{3}{4}g - \frac{1}{3}f$ **G** $\frac{f - g}{f + g}$

4 IN EACH OF THE FOLLOWING, FIND g AND GIVE THE DEGREE OF g , THE DEGREE OF f AND THE DEGREE OF $f - g$.

A $f(x) = 3x - \frac{2}{3}$; $g(x) = 2x + 5$

B $f(x) = -7x^2 + x - 8$; $g(x) = 2x^2 - x + 1$

C $f(x) = 1 - x^3 + 6x^2 - 8x$; $g(x) = x^3 + 10$

5 IN EACH OF THE FOLLOWING,

I FIND THE FUNCTION

II GIVE THE DEGREE OF f AND THE DEGREE OF g

III GIVE THE DEGREE OF $f - g$.

A $f(x) = 2x + 1$; $g(x) = 3x - 5$

B $f(x) = x^2 - 3x + 5$; $g(x) = 5x + 3$

C $f(x) = 2x^3 - x - 7$; $g(x) = x^2 + 2x$

D $f(x) = 0$; $g(x) = x^3 - 8x^2 + 9$

6 IN EACH OF THE FOLLOWING, DIVIDE THE FIRST POLYNOMIAL BY THE SECOND:

A $x^3 - 1$; $x - 1$ **B** $x^3 + 1$; $x^2 - x + 1$

C $x^4 - 1$; $x^2 + 1$ **D** $x^5 + 1$; $x + 1$

E $2x^5 - x^6 + 2x^3 + 6$; $x^3 - x - 2$

7 FOR EACH OF THE FOLLOWING, FIND THE REMAINDER:

A $(5 - 6x + 8x^2) \div (x - 1)$ **B** $(x^3 - 1) \div (x - 1)$

C $(3y - y^2 + 2y^3 - 1) \div (y^2 + 1)$ **D** $(3x^4 + 2x^3 - 4x - 1) \div (x + 3)$

E $(3x^3 - x^2 + x + 2) \div \left(x + \frac{2}{3}\right)$

1.2 THEOREMS ON POLYNOMIALS

1.2.1 Polynomial Division Theorem

RECALL THAT, WHEN WE DIVIDED ONE POLYNOMIAL BY ANOTHER, WE APPLY THE LONG DIVISION PROCEDURE, UNTIL THE REMAINDER WAS EITHER THE ZERO POLYNOMIAL OR A POLYNOMIAL OF DEGREE LESS THAN THE DIVISOR.

FOR EXAMPLE, IF WE DIVIDE $x^2 + 3x + 7$ BY $x + 1$, WE OBTAIN THE FOLLOWING.

$$\begin{array}{r}
 \text{Divisor} \longrightarrow \underline{x + 1} \overline{) x^2 + 3x + 7} \longleftarrow \text{dividend} \\
 \underline{x^2 + x} \\
 2x + 7 \\
 \underline{2x + 2} \\
 5 \longleftarrow \text{remainder}
 \end{array}$$

$x + 2 \longleftarrow$ quotient

IN FRACTIONAL FORM, WE CAN WRITE THIS RESULT AS FOLLOWS

$$\frac{\overbrace{x^2 + 3x + 7}^{\text{dividend}}}{\underbrace{x + 1}_{\text{divisor}}} = \overbrace{x + 2}^{\text{quotient}} + \frac{\underbrace{5}_{\text{remainder}}}{\underbrace{x + 1}_{\text{divisor}}}$$

THIS IMPLIES THAT $x^2 + 3x + 7 = (x + 1)(x + 2) + 5$ WHICH ILLUSTRATES THE THEOREM CALLED THE **polynomial division theorem**.

ACTIVITY 1.6



- 1 FOR EACH OF THE FOLLOWING PAIRS OF POLYNOMIALS, FIND $q(x)$ AND $r(x)$ THAT SATISFY $f(x) = d(x)q(x) + r(x)$.
 - A $f(x) = x^2 + x - 7$; $d(x) = x - 3$
 - B $f(x) = x^3 - x^2 + 8$; $d(x) = x + 2$
 - C $f(x) = x^4 - x^3 + x - 1$; $d(x) = x - 1$
- 2 IN QUESTION 1, WHAT DID YOU OBSERVE ABOUT THE DEGREE OF THE POLYNOMIALS $f(x)$ AND $d(x)$?
- 3 IN QUESTION 1, THE FRACTIONAL EXPRESSION $\frac{f(x)}{d(x)}$ IS IMPROPER. WHY?
- 4 IS $\frac{r(x)}{d(x)}$ PROPER OR IMPROPER? WHAT CAN YOU SAY ABOUT THE DEGREE OF $r(x)$ AND $d(x)$?

Theorem 1.1 Polynomial division theorem

If $f(x)$ and $d(x)$ are polynomials such that $d(x) \neq 0$, and the degree of $d(x)$ is less than or equal to the degree of $f(x)$, then there exist unique polynomials $q(x)$ and $r(x)$ such that

$$f(x) = d(x)q(x) + r(x)$$

\downarrow \downarrow \downarrow \downarrow
Dividend **Quotient**
 \downarrow \downarrow
Divisor **Remainder**

where $r(x) = 0$ or the degree of $r(x)$ is less than the degree of $d(x)$. If the remainder $r(x)$ is zero, $f(x)$ divides exactly into $d(x)$.

Proof:-

I Existence of the polynomials $q(x)$ and $r(x)$

SINCE $f(x)$ AND $d(x)$ ARE POLYNOMIALS, LONG DIVISION OF WILL GIVE A QUOTIENT AND REMAINDER WITH DEGREE OF DEGREE OF OR $r(x) = 0$.

II The uniqueness of $q(x)$ and $r(x)$

TO SHOW THE UNIQUENESS OF $q(x)$ AND $r(x)$, SUPPOSE THAT

$$f(x) = d(x)q_1(x) + r_1(x) \text{ AND ALSO}$$

$$f(x) = d(x)q_2(x) + r_2(x) \text{ WITH } \text{DEG}(r_2) < \text{DEG}(d) \text{ AND } \text{DEG}(r_1) < \text{DEG}(d).$$

THEN $r_2(x) = f(x) - d(x)q_2(x)$ AND $r_1(x) = f(x) - d(x)q_1(x)$

$$\Rightarrow r_2(x) - r_1(x) = d(x)[q_1(x) - q_2(x)]$$

THEREFORE $d(x)$ IS A FACTOR OF $r_2(x) - r_1(x)$

AS $\text{DEG}(r_2(x) - r_1(x)) \leq \max\{\text{DEG}(r_2(x)), \text{DEG}(r_1(x))\} < \text{DEG}(d(x))$ IT FOLLOWS THAT,

$$r_2(x) - r_1(x) = 0$$

AS A RESULT $r_2(x) = r_1(x)$ AND $q_1(x) = q_2(x)$.

THEREFORE $q(x)$ AND $r(x)$ ARE UNIQUE POLYNOMIAL FUNCTIONS.

EXAMPLE 1 IN EACH OF THE FOLLOWING PAIRS OF POLYNOMIALS, FIND $q(x)$ AND $r(x)$ SUCH THAT $f(x) = d(x)q(x) + r(x)$.

- A** $f(x) = 2x^3 - 3x + 1; d(x) = x + 2$
- B** $f(x) = x^3 - 2x^2 + x + 5; d(x) = x^2 + 1$
- C** $f(x) = x^4 + x^2 - 2; d(x) = x^2 - x + 3$

SOLUTION:

A
$$\frac{f(x)}{d(x)} = \frac{2x^3 - 3x + 1}{x + 2} = 2x^2 - 4x + 5 - \frac{9}{x + 2}$$

$$\Rightarrow 2x^3 - 3x + 1 = (x + 2)(2x^2 - 4x + 5) - 9$$

THEREFORE $q(x) = 2x^2 - 4x + 5$ AND $r(x) = -9$.

B
$$\frac{f(x)}{d(x)} = \frac{x^3 - 2x^2 + x + 5}{x^2 + 1} = x - 2 + \frac{7}{x^2 + 1}$$

$$\Rightarrow x^3 - 2x^2 + x + 5 = (x^2 + 1)(x - 2) + 7$$

THEREFORE $q(x) = x - 2$ AND $r(x) = 7$.

C
$$\frac{f(x)}{d(x)} = \frac{x^4 + x^2 - 2}{x^2 - x + 3} = x^2 + x - 1 + \frac{-4x + 1}{x^2 - x + 3}$$

$$\Rightarrow x^4 + x^2 - 2 = (x^2 - x + 3)(x^2 + x - 1) + (-4x + 1)$$

GIVING $q(x) = x^2 + x - 1$ AND $r(x) = -4x + 1$.

Exercise 1.4

1 FOR EACH OF THE FOLLOWING PAIRS OF POLYNOMIALS, FIND $q(x)$ AND $r(x)$ THAT SATISFY THE REQUIREMENTS OF THE POLYNOMIAL DIVISION THEOREM.

- A** $f(x) = x^2 - x + 7; d(x) = x + 1$
- B** $f(x) = x^3 + 2x^2 - 5x + 3; d(x) = x^2 + x - 1$
- C** $f(x) = x^2 + 8x - 12; d(x) = 2$

2 IN EACH OF THE FOLLOWING, EXPRESS THE FUNCTION $f(x)$ IN THE FORM

$$f(x) = (x - c)q(x) + r(x)$$
 FOR THE GIVEN NUMBER

- A** $f(x) = x^3 - 5x^2 - x + 8; c = -2$
- B** $f(x) = x^3 + 2x^2 - 2x - 14; c = \frac{1}{2}$

3 PERFORM THE FOLLOWING DIVISIONS, ASSUMING n IS A POSITIVE INTEGER:

- A**
$$\frac{x^{3n} + 5x^{2n} + 12x^n + 18}{x^n + 3}$$
- B**
$$\frac{x^{3n} - x^{2n} + 3x^n - 10}{x^n - 2}$$

1.2.2 Remainder Theorem

THE EQUALITY $f(x) = d(x)q(x) + r(x)$ EXPRESSES THE FACT THAT

Dividend = (divisor) (quotient) + remainder.

ACTIVITY 1.7

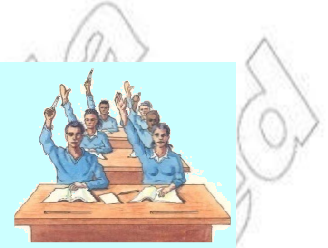

- 1 LET $f(x) = x^4 - x^3 - x^2 - x - 2$.
 - A FIND $f(-2)$ AND $f(2)$.
 - B WHAT IS THE REMAINDER WHEN $f(x)$ IS DIVIDED BY 2?
 - C IS THE REMAINDER EQUAL TO $f(2)$?
 - D WHAT IS THE REMAINDER WHEN $f(x)$ IS DIVIDED BY $x - 2$?
 - E IS THE REMAINDER EQUAL TO $f(2)$?
- 2 IN EACH OF THE FOLLOWING, FIND THE REMAINDER WHEN THE POLYNOMIAL IS DIVIDED BY THE POLYNOMIAL OR THE GIVEN NUMBER. ALSO, FIND $f(c)$.

A $f(x) = 2x^2 + 3x + 1; c = -1$	B $f(x) = x^6 + 1; c = -1, 1$
C $f(x) = 3x^3 - x^4 + 2; c = 2$	D $f(x) = x^3 - x + 1; c = -1, 1$

Theorem 1.2 Remainder theorem

Let $f(x)$ be a polynomial of degree greater than or equal to 1 and let c be any real number. If $f(x)$ is divided by the linear polynomial $(x - c)$, then the remainder is $f(c)$.

Proof:-

WHEN $f(x)$ IS DIVIDED BY $(x - c)$, THE REMAINDER IS ALWAYS A CONSTANT. WHY?
 BY THE POLYNOMIAL DIVISION THEOREM

$$f(x) = (x - c)q(x) + k$$

WHERE k IS CONSTANT. THIS EQUATION HOLDS FOR EVERY REAL NUMBER WHEN $x = c$.

IN PARTICULAR, IF YOU OBSERVE A VERY INTERESTING AND USEFUL RELATIONSHIP

$$\begin{aligned} f(c) &= (c - c)q(c) + k \\ &= 0 \cdot q(c) + k \\ &= 0 + k = k \end{aligned}$$

IT FOLLOWS THAT THE VALUE OF THE POLYNOMIAL IS THE SAME AS THE REMAINDER OBTAINED WHEN YOU DIVIDE $f(x)$ BY $(x - c)$.

EXAMPLE 2 FIND THE REMAINDER BY DIVIDING f IN EACH OF THE FOLLOWING PAIRS OF POLYNOMIALS, USING THE POLYNOMIAL DIVISION AND THE REMAINDER THEOREM

A $f(x) = x^3 - x^2 + 8x - 1; d(x) = x + 2$

B $f(x) = x^4 + x^2 + 2x + 5; d(x) = x - 1$

SOLUTION:

A Polynomial division theorem

$$\begin{aligned} & \frac{x^3 - x^2 + 8x - 1}{x + 2} \\ &= x^2 - 3x + 14 - \frac{29}{x + 2} \end{aligned}$$

Remainder theorem

$$\begin{aligned} f(-2) &= (-2)^3 - (-2)^2 + 8(-2) - 1, \\ &= -8 - 4 - 16 - 1 = -29 \end{aligned}$$

THEREFORE, THE REMAINDER IS -29 .

B Polynomial division theorem

$$\begin{aligned} & \frac{x^4 + x^2 + 2x + 5}{x - 1} \\ &= x^3 + x^2 + 2x + 4 + \frac{9}{x - 1} \end{aligned}$$

Remainder theorem

$$\begin{aligned} f(1) &= (1)^4 + (1)^2 + 2(1) + 5 \\ &= 1 + 1 + 2 + 5 = 9 \end{aligned}$$

THEREFORE, THE REMAINDER IS 9 .

EXAMPLE 3 WHEN $x^3 - 2x^2 + 3bx + 10$ IS DIVIDED BY $3x$ THE REMAINDER IS 37 . FIND THE VALUE OF b

SOLUTION: LET $f(x) = x^3 - 2x^2 + 3bx + 10$.

$f(3) = 37$. (BY THE REMAINDER THEOREM)

$$\Rightarrow (3)^3 - 2(3)^2 + 3b(3) + 10 = 37$$

$$27 - 18 + 9b + 10 = 37 \Rightarrow 9b + 19 = 37 \Rightarrow b = 2.$$

Exercise 1.5

1 IN EACH OF THE FOLLOWING, EXPRESS THE FORM IN

$$f(x) = (x - c)q(x) + r(x)$$

FOR THE GIVEN NUMBER. SHOW THAT r IS THE REMAINDER.

A $f(x) = x^3 - x^2 + 7x + 11; c = 2$

B $f(x) = 1 - x^5 + 2x^3 + x; c = -1$

C $f(x) = x^4 + 2x^3 + 5x^2 + 1; c = -\frac{2}{3}$

- 2 IN EACH OF THE FOLLOWING, USE THE REMAINDER THEOREM TO FIND THE REMAINDER WHEN THE POLYNOMIAL IS DIVIDED BY c FOR THE GIVEN NUMBER c
- A $f(x) = x^{17} - 1; c = 1$ B $f(x) = 2x^2 + 3x + 1; c = -\frac{1}{2}$
- C $f(x) = x^{23} + 1; c = -1$
- 3 WHEN $f(x) = 3x^7 - ax^6 + 5x^3 - x + 11$ IS DIVIDED BY 1, THE REMAINDER IS 15. WHAT IS THE VALUE OF a
- 4 WHEN THE POLYNOMIAL $ax^3 + bx^2 - 2x + 8$ IS DIVIDED BY 1 AND $x + 1$ THE REMAINDERS ARE 3 AND 5 RESPECTIVELY. FIND THE VALUES OF

1.2.3 Factor Theorem

RECALL THAT **factorizing** a polynomial means writing it as a product of two or more polynomials. YOU WILL DISCUSS BELOW AN INTERESTING THEOREM, KNOWN AS **theorem**, WHICH IS HELPFUL IN CHECKING WHETHER A LINEAR POLYNOMIAL IS A FACTOR OF A GIVEN POLYNOMIAL OR NOT.

ACTIVITY 1.8



- 1 LET $f(x) = x^3 - 5x^2 + 2x + 8$.
- A FIND $f(2)$.
- B WHAT IS THE REMAINDER WHEN DIVIDED BY 2?
- C IS $x - 2$ A FACTOR OF f
- D FIND $f(-1)$ AND $f(1)$.
- E EXPRESS $f(x)$ AS $f(x) = (x - c)q(x)$ WHERE $q(x)$ IS THE QUOTIENT.
- 2 LET $f(x) = x^3 - 3x^2 - x + 3$.
- A WHAT ARE THE VALUES OF $f(1)$ AND $f(3)$?
- B WHAT DOES THIS TELL US ABOUT THE REMAINDERS WHEN 1, $x - 1$ AND -3 ?
- C HOW CAN THIS HELP US IN FACTORIZING

Theorem 1.3 Factor theorem

Let $f(x)$ be a polynomial of degree greater than or equal to one, and let c be any real number, then

- I $x - c$ is a factor of $f(x)$, if $f(c) = 0$, and
- II $f(c) = 0$, if $x - c$ is a factor of $f(x)$.

TRY TO DEVELOP A PROOF OF THIS THEOREM USING THE REMAINDER THEOREM

Group Work 1.2



- 1 LET $f(x) = 4x^4 - 5x^2 + 1$.
- A** FIND $f(-1)$ AND SHOW THAT 1 IS A FACTOR OF $f(x)$.
- B** SHOW THAT 2 IS A FACTOR OF $f(x)$.
- C** TRY TO COMPLETELY FACTORIZE $f(x)$ INTO LINEAR FACTORS.
- 2 GIVE THE PROOF OF THE FACTOR THEOREM

Hint: YOU HAVE TO PROVE THAT

I IF $f(c) = 0$, THEN $x - c$ IS A FACTOR OF $f(x)$

II IF $x - c$ IS A FACTOR OF $f(x)$, THEN $f(c) = 0$

USE THE POLYNOMIAL DIVISION THEOREM WITH FACTOR $(x - c)$ TO EXPRESS $f(x)$ AS

$$f(x) = d(x)q(x) + r(x), \text{ WHERE } d(x) = x - c.$$

USE THE REMAINDER THEOREM $r(x) = k = f(c)$, GIVING YOU

$$f(x) = (x - c)q(x) + f(c)$$

WHERE $q(x)$ IS A POLYNOMIAL OF DEGREE LESS THAN THE DEGREE OF $f(x)$.

IF $f(c) = 0$, THEN WHAT WILL $r(x)$ BE? COMPLETE THE PROOF.

EXAMPLE 4 LET $f(x) = x^3 + 2x^2 - 5x - 6$. USE THE FACTOR THEOREM TO DETERMINE WHETHER:

- A** $x + 1$ IS A FACTOR OF $f(x)$ **B** $x + 2$ IS A FACTOR OF $f(x)$

SOLUTION:

A SINCE $x + 1 = x - (-1)$, IT HAS THE FORM WITH $c = -1$.

$$f(-1) = (-1)^3 + 2(-1)^2 - 5(-1) - 6 = -1 + 2 + 5 - 6 = 0.$$

SO, BY THE FACTOR THEOREM $x + 1$ IS A FACTOR OF $f(x)$.

B $f(-2) = (-2)^3 + 2(-2)^2 - 5(-2) - 6 = -8 + 8 + 10 - 6 = 4 \neq 0$.

BY THE FACTOR THEOREM $x + 2$ IS NOT A FACTOR OF $f(x)$.

EXAMPLE 5 SHOW THAT $3x - 2$ AND $x + 1$ ARE FACTORS AND 3 IS NOT A FACTOR OF $f(x) = x^4 + x^3 - 7x^2 - x + 6$.

SOLUTION: $f(-3) = (-3)^4 + (-3)^3 - 7(-3)^2 - (-3) + 6 = 81 - 27 - 63 + 3 + 6 = 0$.

HENCE $x + 3$ IS A FACTOR OF $f(x)$.

$$f(2) = 2^4 + (2)^3 - 7(2)^2 - 2 + 6 = 16 + 8 - 28 - 2 + 6 = 0.$$

HENCE -2 IS A FACTOR OF $f(x)$

$$f(-1) = (-1)^4 + (-1)^3 - 7(-1)^2 - (-1) + 6 = 1 - 1 - 7 + 1 + 6 = 0$$

HENCE $+1$ IS A FACTOR OF $f(x)$

$$f(-2) = (-2)^4 + (-2)^3 - 7(-2)^2 - (-2) + 6 = 16 - 8 - 28 + 2 + 6 = -12 \neq 0$$

HENCE $+2$ IS NOT A FACTOR OF $f(x)$

Exercise 1.6

1 IN EACH OF THE FOLLOWING, USE THE TEST TO DETERMINE WHETHER OR NOT IS A FACTOR OF

A $g(x) = x + 1; f(x) = x^{15} + 1$

B $g(x) = x - 1; f(x) = x^7 + x - 1$

C $g(x) = x - \frac{3}{2}; f(x) = 6x^2 + x - 1$

D $g(x) = x + 2; f(x) = x^3 - 3x^2 - 4x - 12$

2 IN EACH OF THE FOLLOWING, FIND A NUMBER THE GIVEN CONDITION:

A $x - 2$ IS A FACTOR OF $8x^2 - kx + 6$

B $x + 3$ IS A FACTOR OF $x^4 - 6x^3 - x^2 + 4x + 29$

C $3x - 2$ IS A FACTOR OF $4x^2 + kx - k$

3 FIND NUMBERS a AND k SO THAT $x + 2$ IS A FACTOR OF $fx^4 - 2ax^3 + ax^2 - x + k$ AND $f(-1) = 3$.

4 FIND A POLYNOMIAL FUNCTION OF DEGREE 3 SUCH THAT, x AND $x + 2$ ARE FACTORS OF THE POLYNOMIAL.

5 LET n BE A REAL NUMBER AND n POSITIVE INTEGER. SHOW THAT $x + 1$ IS A FACTOR OF $x^n - 1$.

6 SHOW THAT k AND $k + 1$ ARE FACTORS OF $x^2 - 2x + 1$ AND $x + 1$ IS NOT A FACTOR OF $x^2 - 2x + 1$.

7 IN EACH OF THE FOLLOWING, FIND THE CONSTANT IN THE DENOMINATOR WILL DIVIDE THE NUMERATOR EXACTLY:

A $\frac{x^3 + 3x^2 - 3x + c}{x - 3}$

B $\frac{x^3 - 2x^2 + x + c}{x + 2}$

8 THE AREA OF A RECTANGLE IN SQUARE FEET IS 36. HOW MUCH LONGER IS THE LENGTH THAN THE WIDTH OF THE RECTANGLE?

1.3 ZEROS OF A POLYNOMIAL FUNCTION

IN THIS SECTION, YOU WILL DISCUSS AN INTERESTING CONCEPT KNOWN AS ZEROS OF A POLYNOMIAL. AS CONSIDER THE POLYNOMIAL FUNCTION

WHAT IS (1)? NOTE THAT $f(1) = 1 - 1 = 0$.

AS $f(1) = 0$, WE SAY THAT 1 IS THE ZERO OF THE POLYNOMIAL FUNCTION

TO FIND THE ZERO OF A LINEAR (FIRST DEGREE POLYNOMIAL) FUNCTION OF THE FORM $f(x) = ax + b$, $a \neq 0$, WE FIND THE NUMBER WHICH $f(x) = 0$.

NOTE THAT EVERY LINEAR FUNCTION HAS EXACTLY ONE ZERO

$$ax + b = 0 \Rightarrow ax = -b \text{ Subtracting } b \text{ from both sides}$$

$$\Rightarrow x = -\frac{b}{a} \text{ Dividing both sides by } a, \text{ since } a \neq 0.$$

THEREFORE, $-\frac{b}{a}$ IS THE ONLY ZERO OF THE LINEAR FUNCTION.

EXAMPLE 1 FIND THE ZEROS OF THE POLYNOMIAL $f(x) = \frac{2x-1}{3} - \frac{x+2}{3} - 2$.

SOLUTION: $f(x) = 0 \Rightarrow \frac{2x-1}{3} - \frac{x+2}{3} = 2$

$$2x - 1 - (x + 2) = 6 \Rightarrow 2x - 1 - x - 2 = 6 \Rightarrow x = 9.$$

SO, 9 IS THE ZERO OF

SIMILARLY, TO FIND THE ZEROS OF A QUADRATIC FUNCTION (SECOND DEGREE POLYNOMIAL) OF THE FORM $f(x) = ax^2 + bx + c$, $a \neq 0$, WE FIND THE NUMBER WHICH

$$ax^2 + bx + c = 0, a \neq 0.$$

ACTIVITY 1.9

1 FIND THE ZEROS OF EACH OF THE FOLLOWING FUNCTION

A $h(x) = 1 - \frac{3}{5}(x + 2)$ **B** $k(x) = 2 - (x^2 - 4) + x^2 - 4x$

C $f(x) = 4x^2 - 25$ **D** $f(x) = x^2 + x - 12$

E $f(x) = x^3 - 2x^2 + x$ **F** $g(x) = x^3 + x^2 - x - 1$

2 HOW MANY ZEROS CAN A QUADRATIC FUNCTION HAVE?

3 STATE TECHNIQUES FOR FINDING ZEROS OF A QUADRATIC FUNCTION

4 HOW MANY ZEROS CAN A POLYNOMIAL FUNCTION HAVE OF DEGREE ABOUT DEGREE 4?

EXAMPLE 2 FIND THE ZEROS OF EACH OF THE FOLLOWING QUADRATIC FUNCTIONS

A $f(x) = x^2 - 16$ **B** $g(x) = x^2 - x - 6$ **C** $h(x) = 4x^2 - 7x + 3$



SOLUTION:

A $f(x) = 0 \Rightarrow x^2 - 16 = 0 \Rightarrow x^2 - 4^2 = 0 \Rightarrow (x - 4)(x + 4) = 0$
 $\Rightarrow x - 4 = 0$ OR $x + 4 = 0 \Rightarrow x = 4$ OR $x = -4$

THEREFORE, -4 AND 4 ARE THE ZEROS OF

B $g(x) = 0 \Rightarrow x^2 - x - 6 = 0$

FIND TWO NUMBERS WHOSE SUM IS -1 AND WHOSE PRODUCT IS -6 . THESE ARE -3

$x^2 - 3x + 2x - 6 = 0 \Rightarrow x(x - 3) + 2(x - 3) = 0 \Rightarrow (x + 2)(x - 3) = 0$

$\Rightarrow x + 2 = 0$ OR $x - 3 = 0 \Rightarrow x = -2$ OR $x = 3$

THEREFORE, -2 AND 3 ARE THE ZEROS OF g

C $h(x) = 0 \Rightarrow 4x^2 - 7x + 3 = 0$

FIND TWO NUMBERS WHOSE SUM IS -7 AND WHOSE PRODUCT IS 12 . THESE ARE -4 AND

HENCE, $4x^2 - 7x + 3 = 0 \Rightarrow 4x^2 - 4x - 3x + 3 = 0 \Rightarrow 4x(x - 1) - 3(x - 1) = 0$

$\Rightarrow (4x - 3)(x - 1) = 0 \Rightarrow 4x - 3 = 0$ OR $x - 1 = 0 \Rightarrow x = \frac{3}{4}$ OR $x = 1$.

THEREFORE, $\frac{3}{4}$ AND 1 ARE THE ZEROS OF h

Definition 1.2

For a polynomial function f and a real number c , if

$f(c) = 0$, then c is a **zero** of f .

NOTE THAT IF $f(x) = (x - c)g(x)$, THEN c IS A ZERO OF $f(x)$.

EXAMPLE 3

A USE THE FACTOR THEOREM TO SHOW THAT $x + 1$ IS A FACTOR OF $f(x) = x^{25} + 1$.

B WHAT ARE THE ZEROS OF $f(x) = (x - 5)(x + 2)(x - 1)$?

C WHAT ARE THE REAL ZEROS OF

D DETERMINE THE ZEROS OF $f(x) = 3x^2 + 1$.

SOLUTION:

A SINCE $x + 1 = x - (-1)$, WE HAVE -1 AND

$f(-1) = (-1)^{25} + 1 = -1 + 1 = 0$

HENCE, -1 IS A ZERO OF $f(x) = x^{25} + 1$, BY THE FACTOR THEOREM

SO $x - (-1) = x + 1$ IS A FACTOR OF $f(x)$.

B SINCE $(x - 5)$, $(x + 2)$ AND $(x - 1)$ ARE ALL FACTORS OF $f(x)$, 5 , -2 AND 1 ARE THE ZEROS OF $f(x)$.

C FACTORISING THE LEFT SIDE, WE HAVE

$$x^4 - 1 = 0 \Rightarrow (x^2 - 1)(x^2 + 1) = 0 \Rightarrow (x - 1)(x + 1)(x^2 + 1) = 0$$

SO THE REAL ZEROS OF $x^4 - 1$ ARE -1 AND 1 .

D $f(x) = 0 \Rightarrow 2x^4 - 3x^2 + 1 = 0 \Rightarrow 2(x^2)^2 - 3x^2 + 1 = 0$

LET $y = x^2$. THEN $2y^2 - 3y + 1 = 0 \Rightarrow 2y^2 - 3y + 1 = 0 \Rightarrow (2y - 1)(y - 1) = 0$
 $\Rightarrow 2y - 1 = 0$ OR $y - 1 = 0$

HENCE $y = \frac{1}{2}$ OR $y = 1$

SINCE $y = x^2$, WE HAVE $x^2 = \frac{1}{2}$ OR $x^2 = 1$.

THEREFORE $x = \pm \sqrt{\frac{1}{2}}$ OR $x = \pm 1$. (Note that $\sqrt{\frac{1}{2}} = \frac{\sqrt{2}}{2}$.)

HENCE, $\frac{\sqrt{2}}{2}$, $\frac{\sqrt{2}}{2}$, -1 AND 1 ARE ZEROS OF

A POLYNOMIAL FUNCTION CANNOT HAVE MORE ZEROS THAN ITS DEGREE.

1.3.1 Zeros and Their Multiplicities

IF $f(x)$ IS A POLYNOMIAL FUNCTION OF DEGREE n , THEN A ROOT OF THE EQUATION

$$f(x) = 0$$

IS CALLED A ZERO OF $f(x)$.

BY THE FACTOR THEOREM, EACH ZERO OF A POLYNOMIAL FUNCTION GENERATES A FIRST DEGREE FACTOR $(x - c)$ OF $f(x)$. WHEN $f(x)$ IS FACTORIZED COMPLETELY, THE SAME FACTOR (OCCUR MORE THAN ONCE, IN WHICH CASE IT IS CALLED A **Multiple zero** OF $f(x)$. IF $x - c$ OCCURS ONLY ONCE, IT IS CALLED A **Simple zero** OF $f(x)$.

Definition 1.3

If $(x - c)^k$ is a factor of $f(x)$, but $(x - c)^{k+1}$ is not, then c is said to be a **zero of multiplicity k** of f .

EXAMPLE 4 GIVEN THAT -1 AND 2 ARE ZEROS OF $x^3 - 3x^2 - 5x - 2$, DETERMINE THEIR MULTIPLICITY.

SOLUTION: BY THE FACTOR THEOREM, $(x + 1)$ AND $(x - 2)$ ARE FACTORS OF

HENCE $f(x)$ CAN BE DIVIDED BY $(x - 2) = x^2 - x - 2$, GIVING YOU

$$f(x) = (x^2 - x - 2)(x^2 + 2x + 1) = (x + 1)(x - 2)(x + 1)^2 = (x + 1)^3(x - 2)$$

THEREFORE, -1 IS A ZERO OF MULTIPLICITY 3 AND 2 IS A ZERO OF MULTIPLICITY 1.

Exercise 1.7

- 1** FIND THE ZEROS OF EACH OF THE FOLLOWING FUNCTIONS:
- A** $f(x) = 1 - \frac{3}{5}x$ **B** $f(x) = \frac{1}{4}(1 - 2x) - (x + 3)$
- C** $g(x) = \frac{2}{3}(2 - 3x)(x - 2)(x + 1)$ **D** $h(x) = x^4 + 7x^2 + 12$
- E** $g(x) = x^3 + x^2 - 2$ **F** $f(t) = t^3 - 7t + 6$
- G** $f(y) = y^5 - 2y^3 + y$ **H** $f(x) = 6x^4 - 7x^2 - 3$
- 2** FOR EACH OF THE FOLLOWING, LIST THE ZEROS OF THE POLYNOMIAL AND STATE THE MULTIPLICITY OF EACH ZERO.
- A** $f(x) = x^{12} \left(x - \frac{2}{3}\right)$ **B** $g(x) = 3(x - \sqrt{2})^2(x + 1)$
- C** $h(x) = 3x^6(x - 1)^5(x - (-1))^3$ **D** $f(x) = 2(x - \sqrt{3})^5(x + 5)^9(1 - 3x)$
- E** $f(x) = x^3 - 3x^2 + 3x - 1$
- 3** FIND A POLYNOMIAL FUNCTION OF DEGREE 3 SUCH THAT 17 AND THE ZEROS OF ARE 0, 5 AND 8.
- 4** IN EACH OF THE FOLLOWING, THE INDICATED NUMBER IS A ZERO OF A POLYNOMIAL FUNCTION $f(x)$. DETERMINE THE MULTIPLICITY OF THIS ZERO.
- A** 1; $f(x) = x^3 + x^2 - 5x + 3$ **B** -1; $f(x) = x^4 + 3x^3 + 3x^2 + x$
- C** $\frac{1}{2}$; $f(x) = 4x^3 - 4x^2 + x$.
- 5** SHOW THAT IF 4 IS A FACTOR OF SOME POLYNOMIAL, THEN $\frac{4}{3}$ IS A ZERO OF
- 6** IN EACH OF THE FOLLOWING, FIND A POLYNOMIAL HAVING THE GIVEN ZEROS SATISFYING THE GIVEN CONDITION.
- A** 0, 3, 4 AND $f(1) = 5$ **B** $-1, 1 + \sqrt{2}, 1 - \sqrt{2}$ AND $f(0) = 1$
- 7** A POLYNOMIAL FUNCTION OF DEGREE 3 HAS ZEROS $\frac{1}{2}$ AND 1 AND ITS LEADING COEFFICIENT IS NEGATIVE. WRITE AN EXPRESSION FOR DIFFERENT POLYNOMIAL FUNCTIONS ARE POSSIBLE FOR

8 IF $p(x)$ IS A POLYNOMIAL OF DEGREE 3 WITH $p(-1) = 0$ AND $p(2) = 6$, THEN

A SHOW THAT $p(x) = -p(-x)$.

B FIND THE INTERVAL IN WHICH $p(x)$ IS LESS THAN ZERO.

9 FIND THE VALUES OF p AND q IF $x - 1$ IS A COMMON FACTOR OF

$$f(x) = x^4 - px^3 + 7qx + 1, \text{ AND } g(x) = x^6 - 4x^3 + px^2 + qx - 3.$$

10 THE HEIGHT ABOVE GROUND LEVEL IN METRES OF A MISSILE LAUNCHED VERTICALLY, IS GIVEN BY

$$h(t) = -16t^3 + 100t.$$

AT WHAT TIME IS THE MISSILE 72 M ABOVE GROUND LEVEL [ROUND OFF TO TWO DECIMAL PLACES].

1.3.2 Location Theorem

A POLYNOMIAL FUNCTION WITH RATIONAL COEFFICIENTS MAY HAVE NO RATIONAL ZEROS. FOR EXAMPLE, THE ZEROS OF THE POLYNOMIAL FUNCTION:

$$f(x) = x^2 - 4x - 2 \text{ ARE ALL IRRATIONAL.}$$

CAN YOU WORK OUT WHAT THE ZEROS ARE? THE POLYNOMIAL FUNCTION $f(x) = x^2 - 4x - 2$ HAS RATIONAL AND IRRATIONAL ZEROS, CAN YOU CHECK THIS?

ACTIVITY 1.10

1 IN EACH OF THE FOLLOWING, DETERMINE WHETHER THE ZEROS OF THE CORRESPONDING FUNCTION ARE RATIONAL, IRRATIONAL OR BOTH.

A $f(x) = x^2 + 2x + 2$

B $f(x) = x^3 + x^2 - 2x - 2$

C $f(x) = (x + 1)(2x^2 + x - 3)$

D $f(x) = x^4 - 5x^2 + 6$

2 FOR EACH OF THE FOLLOWING POLYNOMIALS, COMPLETE TABLE 4.4:

A $f(x) = 3x^3 + x^2 + x - 2$

B $f(x) = x^4 - 6x^3 + x^2 + 12x - 6$

MOST OF THE STANDARD METHODS FOR FINDING THE IRRATIONAL ZEROS OF A POLYNOMIAL INVOLVE A TECHNIQUE OF SUCCESSIVE APPROXIMATION. ONE OF THE METHODS IS BASED ON THE IDEA OF **Change of sign** OF A FUNCTION. CONSEQUENTLY, THE FOLLOWING THEOREM IS

Theorem 1.4 Location theorem

Let a and b be real numbers such that $a < b$. If f is a polynomial function such that $f(a)$ and $f(b)$ have opposite signs, then there is at least one zero of f between a and b .

THIS THEOREM HELPS US TO LOCATE THE REAL ZEROS OF A POLYNOMIAL FUNCTION. IT IS POSSIBLE TO ESTIMATE THE ZEROS OF A POLYNOMIAL FUNCTION FROM A TABLE OF VALUES.

EXAMPLE 5 Let $f(x) = x^4 - 6x^3 + x^2 + 12x - 6$. CONSTRUCT A TABLE OF VALUES AND USE THE LOCATION THEOREM TO LOCATE THE ZEROS BETWEEN SUCCESSIVE INTEGERS.

SOLUTION: CONSTRUCT A TABLE AND LOOK FOR CHANGES IN SIGN AS FOLLO

x	-3	-2	-1	0	1	2	3	4	5	6
$f(x)$	210	38	-10	-6	2	-10	-42	-70	-44	102

SINCE $f(-2) = 38 > 0$ AND $f(-1) = -10 < 0$, WE SEE THAT THE VALUE CHANGES FROM POSITIVE TO NEGATIVE BETWEEN -2 AND -1. HENCE, BY THE THERE IS A ZERO BETWEEN -2 AND -1.

SINCE $f(0) = -6 < 0$ AND $f(1) = 2 > 0$, THERE IS ALSO ONE ZERO BETWEEN 0 AND 1.

SIMILARLY, THERE ARE ZEROS BETWEEN 5 AND 6.

EXAMPLE 6 USING THE LOCATION THEOREM, SHOW THAT THE POLYNOMIAL

$$f(x) = x^5 - 2x^2 - 1 \text{ HAS A ZERO BETWEEN } 1 \text{ AND } 2.$$

SOLUTION: $f(1) = (1)^5 - 2(1)^2 - 1 = 1 - 2 - 1 = -2 < 0$.

$$f(2) = (2)^5 - 2(2)^2 - 1 = 32 - 8 - 1 = 23 > 0.$$

HERE, $f(1)$ IS NEGATIVE AND $f(2)$ IS POSITIVE. THEREFORE, THERE IS A ZERO BETWEEN 1 AND 2.

Exercise 1.8

1 IN EACH OF THE FOLLOWING, USE THE LOCATION THEOREM TO LOCATE ZEROS OF:

A

x	-5	-3	-1	0	2	5
$f(x)$	7	4	2	-1	3	-6

B

x	-6	-5	-4	-3	-2	-1	0	1	2
$f(x)$	-21	-10	8	-1	-5	6	4	-3	18

2 USE THE LOCATION THEOREM TO VERIFY THAT $f(x)$ HAS A ZERO BETWEEN a AND b :

A $f(x) = 3x^3 + 7x^2 + 3x + 7$; $a = -3$, $b = -2$

B $f(x) = 4x^4 + 7x^3 - 11x^2 + 7x - 15$; $a = 1$, $b = \frac{3}{2}$

C $f(x) = -x^4 + x^3 + 1$; $a = -1$, $b = 1$

D $f(x) = x^5 - 2x^3 - 1$; $a = 1$, $b = 2$

- 3 IN EACH OF THE FOLLOWING, USE THE LOCATION THEOREM TO FIND EACH REAL ZERO OF BETWEEN SUCCESSIVE INTEGERS:
- A $f(x) = x^3 - 9x^2 + 23x - 14$; FOR $0 \leq x \leq 6$
 - B $f(x) = x^3 - 12x^2 + x + 2$; FOR $0 \leq x \leq 8$
 - C $f(x) = x^4 - x^2 + x - 1$; FOR $-3 \leq x \leq 3$
 - D $f(x) = x^4 + x^3 - x^2 - 11x + 3$; FOR $-3 \leq x \leq 3$
- 4 IN EACH OF THE FOLLOWING, FIND ALL THE REAL ZEROS OF THE FUNCTION, FOR $-4 \leq x \leq 4$:
- A $f(x) = x^4 - 5x^3 + \frac{15}{2}x^2 - 2x - 2$
 - B $f(x) = x^5 - 2x^4 - 3x^3 + 6x^2 + 2x - 4$
 - C $f(x) = x^4 + x^3 - 4x^2 - 2x + 4$
 - D $f(x) = 2x^4 + x^3 - 10x^2 - 5x$
- 5 IN QUESTION 1 OF EXERCISE 1.7 AT WHAT TIME IS THE MISSILE 50 M ABOVE THE GROUND LEVEL?
- 6 IS IT POSSIBLE FOR A POLYNOMIAL FUNCTION WITH INTEGER COEFFICIENTS TO HAVE NO REAL ZEROS? EXPLAIN YOUR ANSWER.

1.3.3 Rational Root Test

THE **rational root test** RELATES THE POSSIBLE RATIONAL ZEROS OF A POLYNOMIAL COEFFICIENTS TO THE LEADING COEFFICIENT AND TO THE CONSTANT TERM OF THE POLYNOMIAL.

Theorem 1.5 Rational root test

IF THE RATIONAL NUMBER $\frac{p}{q}$ IN LOWEST TERMS, IS A ZERO OF THE POLYNOMIAL

$$f(x) = a_n x^n + a_{n-1} x^{n-1} + \dots + a_1 x + a_0$$

WITH INTEGER COEFFICIENTS, THEN A FACTOR OF p MUST BE A FACTOR OF a_0 .

ACTIVITY 1.11

- 1 WHAT SHOULD YOU DO FIRST TO USE THE TEST?
- 2 WHAT MUST THE LEADING COEFFICIENT BE FOR ALL THE ZEROS TO BE FACTORS OF THE CONSTANT TERM?
- 3 SUPPOSE THAT ALL OF THE COEFFICIENTS WERE RATIONAL. COULD BE DONE TO CHANGE THE POLYNOMIAL INTO ONE WITH INTEGER COEFFICIENTS? DOES THE RESULTING POLYNOMIAL HAVE THE SAME ZEROS AS THE ORIGINAL?
- 4 THERE IS AT LEAST ONE RATIONAL ZERO IF THE CONSTANT TERM IS ZERO. WHAT IS THIS NUMBER?



EXAMPLE 7 IN EACH OF THE FOLLOWING, FIND ALL THE RATIONAL ZEROS:

A $f(x) = x^3 - x + 1$

B $g(x) = 2x^3 + 9x^2 + 7x - 6$

C $g(x) = \frac{1}{2}x^4 - 2x^3 - \frac{1}{2}x^2 + 2x$

SOLUTION:

A THE LEADING COEFFICIENT IS 1 AND THE CONSTANT TERM IS 1. SINCE THESE ARE FACTORS OF THE CONSTANT TERM, THE POSSIBLE RATIONAL ZEROS ARE ± 1 . USING THE REMAINDER TEST THESE POSSIBLE ZEROS.

$$f(1) = (1)^3 - 1 + 1 = 1 - 1 + 1 = 1$$

$$f(-1) = (-1)^3 - (-1) + 1 = -1 + 1 + 1 = 1$$

SO WE CAN CONCLUDE THAT THE GIVEN POLYNOMIAL HAS NO RATIONAL ZEROS.

B $a_n = a_3 = 2$ AND $a_0 = -6$

POSSIBLE VALUES ARE FACTORS OF -6 . THESE ARE $\pm 1, \pm 2, \pm 3, \pm 6$.

POSSIBLE VALUES ARE FACTORS OF 2. THESE ARE $\pm 1, \pm 2$.

THE POSSIBLE RATIONAL ZEROS $\pm 2, \pm 3, \pm 6, \pm \frac{1}{2}, \pm \frac{3}{2}$.

OF THESE 12 POSSIBLE RATIONAL ZEROS, AT MOST 3 CAN BE THE ZEROS OF

CHECK THAT $f(3) = 0, f(-2) = 0$ AND $f\left(\frac{1}{2}\right) = 0$.

USING THE FACTOR THEOREM, WE CAN FACTORIZE AS:

$$2x^3 + 9x^2 + 7x - 6 = (x + 3)(x + 2)(2x - 1). \text{ SO, } g(x) = 0 \text{ AT}$$

$$x = -3, x = -2 \text{ AND AT } \frac{1}{2}.$$

THEREFORE $-3, -2, \frac{1}{2}$ ARE THE ONLY (RATIONAL) ZEROS OF

C LET $h(x) = 2g(x)$. THUS $h(x)$ WILL HAVE THE SAME ZEROS, BUT HAS INTEGER COEFFICIENTS.

$$h(x) = x^4 - 4x^3 - x^2 + 4x$$

x IS A FACTOR SO $h(x) = x(x^3 - 4x^2 - x + 4) = xk(x)$

$k(x)$ HAS A CONSTANT TERM OF 4 AND LEADING COEFFICIENT OF 1. THE POSSIBLE ZEROS ARE $\pm 2, \pm 4$.

USING THE REMAINDER THEOREM $k(1) = 0$, $k(-1) = 0$ AND $k(4) = 0$

SO, BY THE FACTOR THEOREM $k(x) = (x - 1)(x + 1)(x - 4)$.

HENCE $h(x) = x k(x) = x(x - 1)(x + 1)(x - 4)$ AND

$$g(x) = \frac{1}{2}h(x) = \frac{1}{2}x(x - 1)(x + 1)(x - 4).$$

THEREFORE, THE ZEROS ARE 0, ±1 AND 4.

Exercise 1.9

1 IN EACH OF THE FOLLOWING, FIND THE ZEROS AND MULTIPLICITY OF EACH ZERO. WHAT IS THE DEGREE OF THE POLYNOMIAL?

A $f(x) = (x + 6)(x - 3)^2$ **B** $f(x) = 3(x + 2)^3(x - 1)^2(x + 3)$

C $f(x) = \frac{1}{2}(x - 2)^4(x + 3)^3(1 - x)$ **D** $f(x) = x^4 - 5x^3 + 9x^2 - 7x + 2$

E $f(x) = x^4 - 4x^3 + 7x^2 - 12x + 12$

2 FOR EACH OF THE FOLLOWING POLYNOMIALS, LIST ALL RATIONAL ZEROS:

A $p(x) = x^3 - 2x^2 - 5x + 6$ **B** $p(x) = x^3 - 3x^2 + 6x + 8$

C $p(x) = 3x^3 - 11x^2 + 8x + 4$ **D** $p(x) = 2x^3 + x^2 - 4x - 3$

E $p(x) = 12x^3 - 16x^2 - 5x + 3$

3 IN EACH OF THE FOLLOWING, FIND ALL THE ZEROS OF THE POLYNOMIAL, AND EXPRESS THE POLYNOMIAL IN FACTORIZED FORM:

A $f(x) = x^3 - 5x^2 - x + 5$ **B** $g(x) = 3x^3 + 3x^2 - x - 1$

C $p(t) = t^4 - t^3 - t^2 - t - 2$

4 IN EACH OF THE FOLLOWING, FIND ALL THE RATIONAL ZEROS:

A $p(y) = y^3 + \frac{11}{6}y^2 - \frac{1}{2}y - \frac{1}{3}$ **B** $p(x) = x^4 - \frac{25}{4}x^2 + 9$

C $h(x) = x^4 - \frac{21}{10}x^2 + \frac{3}{5}x$ **D** $p(x) = x^4 + \frac{7}{6}x^3 - \frac{7}{3}x^2 - \frac{5}{2}x$

5 FOR EACH OF THE FOLLOWING, FIND ALL THE RATIONAL ZEROS OF THE POLYNOMIAL EQUATION:

A $2x^3 - 5x^2 + 1 = 0$ **B** $4x^4 + 4x^3 - 9x^2 - x + 2 = 0$

C $2x^5 - 3x^4 - 2x + 3 = 0$

1.4 GRAPHS OF POLYNOMIAL FUNCTIONS

IN YOUR PREVIOUS GRADES, YOU HAVE DISCUSSED HOW TO DRAW GRAPHS OF FUNCTIONS OF DEGREE ZERO, ONE AND TWO. IN THE PRESENT SECTION, YOU WILL LEARN ABOUT GRAPHS OF FUNCTIONS OF DEGREE GREATER THAN TWO.

TO UNDERSTAND PROPERTIES OF POLYNOMIAL FUNCTIONS, TRY THE FOLLOWING

ACTIVITY 1.12



1 SKETCH THE GRAPH OF EACH OF THE FOLLOWING FUNCTIONS

- A** $f(x) = 3$ **B** $f(x) = -2.5$
C $g(x) = x - 2$ **D** $g(x) = -3x + 1$

2 LET $f(x) = x^2 - 4x + 5$

A COPY AND COMPLETE THE TABLE OF VALUES GIVEN BELOW.

x	-2	-1	0	1	2	3	4
$f(x) = x^2 - 4x + 5$							

B PLOT THE POINTS WITH COORDINATES $(x, f(x))$ ON THE COORDINATE PLANE.

C JOIN THE POINTS ABOVE BY A SMOOTH CURVE TO GET THE GRAPH OF $f(x)$. YOU CALL THE GRAPH OF $f(x)$ THE GRAPH OF THE FUNCTION. STATE THE DOMAIN AND RANGE OF $f(x)$.

3 CONSTRUCT A TABLE OF VALUES FOR EACH OF THE FOLLOWING POLYNOMIAL FUNCTIONS AND SKETCH THE GRAPH:

- A** $f(x) = x^2 - 3$ **B** $g(x) = -x^2 - 2x + 1$
C $h(x) = x^3$ **D** $p(x) = 1 - x^4$

WE SHALL DISCUSS SKETCHING THE GRAPHS OF HIGHER DEGREE POLYNOMIAL FUNCTIONS USING THE FOLLOWING EXAMPLES.

EXAMPLE 1 LET US CONSIDER THE FUNCTION $f(x) = x^3 - 3x - 4$.

THIS FUNCTION CAN BE WRITTEN AS $f(x) = x^3 - 3x - 4$

COPY AND COMPLETE THE TABLE OF VALUES BELOW.

x	-3	-2	-1	0	1	2	3
y		-6	-2		-6		14

OTHER POINTS BETWEEN INTEGERS MAY HELP YOU TO DETERMINE THE SHAPE OF THE GRAPH BETTER.

FOR INSTANCE, FOR $x = \frac{1}{2}$

$$y = p\left(\frac{1}{2}\right) = -\frac{43}{8}$$

THEREFORE, THE POINT $\left(\frac{1}{2}, -\frac{43}{8}\right)$ IS ON THE GRAPH. SIMILARLY, FOR

$$x = \frac{5}{2}, y = p\left(\frac{5}{2}\right) = \frac{33}{8}.$$

SO, $\left(\frac{5}{2}, \frac{33}{8}\right)$ IS ALSO ON THE GRAPH OF

PLOT THE POINTS WITH COORDINATES FROM THE TABLE AS SHOWN IN 3A. NOW JOIN THESE POINTS BY A SMOOTH CURVE TO GET THE GRAPH SHOWN IN FIGURE 1.3B

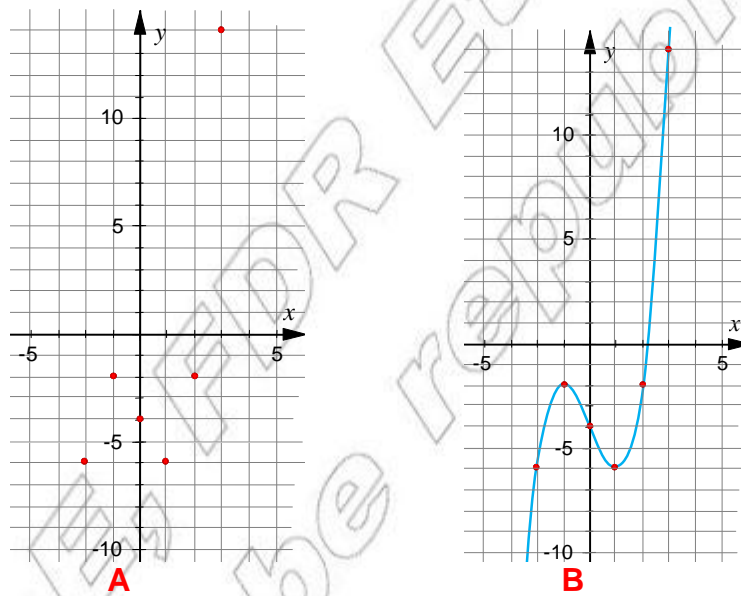

Figure 1.3 Graph of $p(x) = x^3 - 3x - 4$

EXAMPLE 2 SKETCH THE GRAPH OF $-x^4 + 2x^2 + 1$

SOLUTION: TO SKETCH THE GRAPH, WE FIND END POINTS ON THE GRAPH USING A TABLE OF VALUES

x	-2	-1	0	1	2
$y = -x^4 + 2x^2 + 1$	-7	2	1	2	-7

PLOT THE POINTS WITH COORDINATES FROM THIS TABLE AND JOIN THEM BY A SMOOTH CURVE FOR INCREASING x , AS SHOWN IN FIGURE 1.4

FROM THE GRAPH, FIND THE DOMAIN AND THE RANGE. OBSERVE THAT THE GRAPH IS GROWING DOWNWARD.

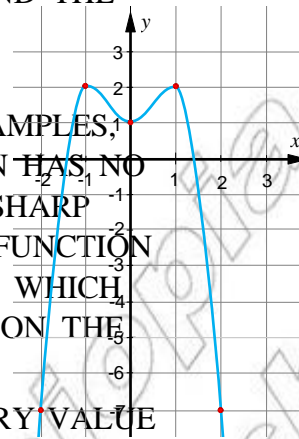

Figure 1.4 Graph of $f(x) = -x^4 + 2x^2 + 1$

AS OBSERVED FROM THE ABOVE TWO EXAMPLES, THE GRAPH OF A POLYNOMIAL FUNCTION HAS NO JUMPS, GAPS AND HOLES. IT HAS NO SHARP CORNERS. THE GRAPH OF A POLYNOMIAL FUNCTION IS A SMOOTH AND CONTINUOUS CURVE WHICH MEANS THERE IS NO BREAK ANYWHERE ON THE GRAPH.

THE GRAPH ALSO SHOWS THAT FOR EVERY VALUE OF x IN THE DOMAIN OF A POLYNOMIAL FUNCTION $f(x)$, THERE IS EXACTLY ONE VALUE WHERE $y = p(x)$.

THE FOLLOWING ARE NOT GRAPHS OF POLYNOMIAL FUNCTIONS.

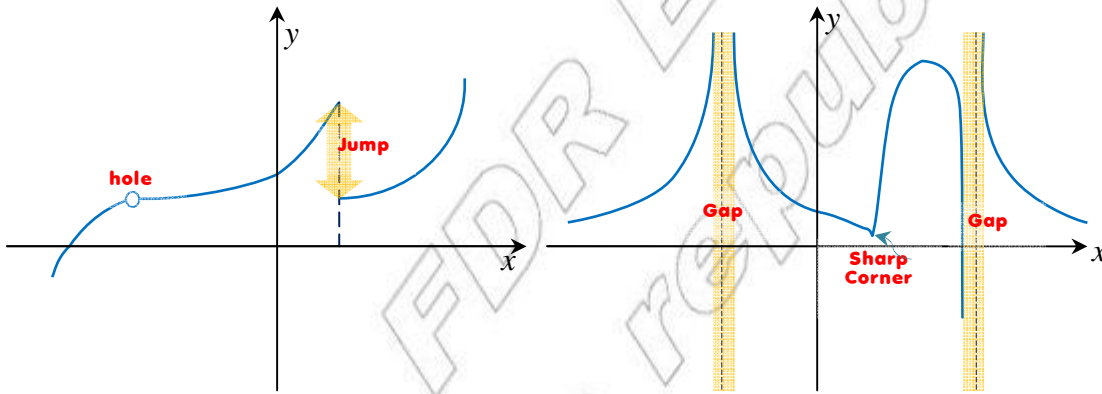

Figure 1.5

FUNCTIONS WITH GRAPHS THAT ARE NOT CONTINUOUS ARE NOT POLYNOMIAL FUNCTIONS.

LOOK AT THE GRAPH OF THE FUNCTION GIVEN IN FIGURE 1.6 IT HAS A SHARP CORNER AT THE POINT $(0, 0)$ AND HENCE $y = |x|$ IS NOT A POLYNOMIAL FUNCTION.

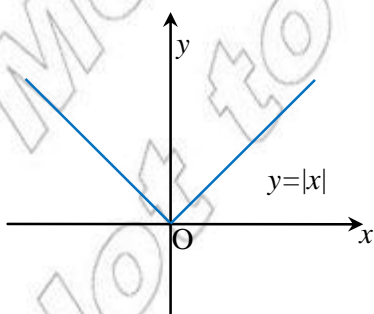

Figure 1.6

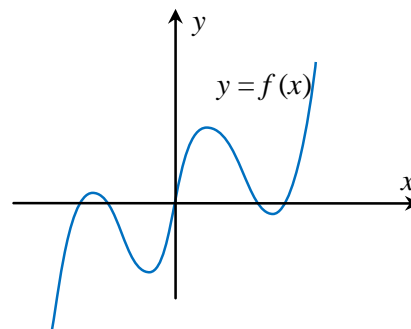

Figure 1.7

Is the function $f(x) = |x - 2|$ a polynomial function? Give reasons for your answer.

THE GRAPH OF THE FUNCTION IN FIGURE 1.7 IS A SMOOTH CURVE. HENCE IT REPRESENTS A POLYNOMIAL FUNCTION. OBSERVE THAT THE RANGE OF

THE POINTS AT WHICH THE GRAPH OF A FUNCTION CROSSES (MEETS) THE COORDINATE AXES ARE IMPORTANT TO NOTE.

IF THE GRAPH OF A FUNCTION CROSSES THE X-AXIS AT $(x_1, 0)$, THEN x_1 IS THE X-INTERCEPT OF THE GRAPH. IF THE GRAPH CROSSES THE Y-AXIS AT THE POINT $(0, y_1)$, THEN y_1 IS THE Y-INTERCEPT OF THE GRAPH.

How do we determine the x-intercept and the y-intercept?

SINCE $(x_1, 0)$ LIES ON THE GRAPH, WE MUST HAVE $f(x_1) = 0$. SO x_1 IS A ZERO OF THE FUNCTION. SIMILARLY, $(0, y_1)$ LIES ON THE GRAPH, WE MUST HAVE $f(0) = y_1$.

CONSIDER THE FUNCTION

$$f(x) = ax + b, a \neq 0$$

What is the x-intercept and the y-intercept?

$$f(x_1) = ax_1 + b = 0. \text{ SOLVING FOR } x_1 \text{ GIVES } ax_1 = -b \Rightarrow x_1 = -\frac{b}{a}$$

SO $-\frac{b}{a}$ IS THE X-INTERCEPT OF THE GRAPH OF THE FUNCTION.

AGAIN, $f(0) = a \cdot 0 + b = b$. THE NUMBER b IS THE Y-INTERCEPT.

TRY TO FIND THE X-INTERCEPT AND THE Y-INTERCEPT OF $f(x) = -3x + 5$.

THE ABOVE METHOD CAN ALSO BE APPLIED TO A QUADRATIC FUNCTION. CONSIDER THE FOLLOWING EXAMPLE.

EXAMPLE 3 FIND THE X-INTERCEPTS AND THE Y-INTERCEPT OF THE GRAPH OF THE FUNCTION

$$f(x) = x^2 - 4x + 3$$

SOLUTION: $f(x_1) = x_1^2 - 4x_1 + 3 = 0 \Rightarrow (x_1 - 1)(x_1 - 3) = 0 \therefore x_1 = 1 \text{ OR } x_1 = 3$

THEREFORE, THE GRAPH HAS TWO X-INTERCEPTS, 1 AND 3.

NEXT $f(0) = 0^2 - 4 \cdot 0 + 3 = 3$. HERE $y_1 = 3$ IS THE Y-INTERCEPT.

THE GRAPH CROSSES THE X-AXIS AT $(1, 0)$ AND $(3, 0)$. IT CROSSES THE Y-AXIS AT $(0, 3)$.

THE GRAPH OPENS UPWARD AND TURNING POINT $(2, -1)$ IS THE VERTEX OR TURNING POINT OF THE GRAPH. THE MINIMUM VALUE OF THE GRAPH IS -1 . THE RANGE OF THE GRAPH IS $\{y : y \geq -1\}$.

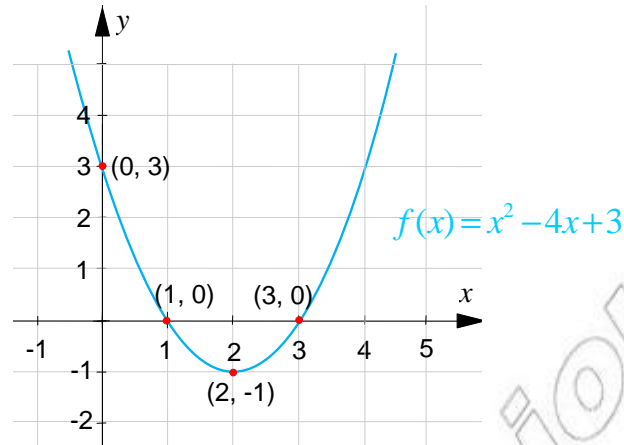

Figure 1.8

NOTE THAT THE GRAPH OF ANY QUADRATIC FUNCTION HAS AT MOST TWO x -INTERCEPTS AND EXACTLY ONE y -INTERCEPT. TRY TO FIND THE REASON.

AS SEEN FROM FIGURE 1.8, $a = 1$ IS POSITIVE AND THE PARABOLA OPENS UPWARD.

What can be stated about the graph of $g(x) = -2x^2 + 4x$?

Does the graph open upward?

The coefficient of x^2 is negative. What is the range of g ?

TO STUDY SOME PROPERTIES OF POLYNOMIALS, WE WILL NOW LOOK AT GRAPHS OF SOME POLYNOMIAL FUNCTIONS OF HIGHER DEGREES OF THE FORM $f(x) = x^n + 1$.

EXAMPLE 4 BY SKETCHING THE GRAPHS OF $f(x) = x^3 + 1$ AND $h(x) = -2x^3 + 1$, OBSERVE THEIR BEHAVIOURS AND GENERALISE YOUR OBSERVATIONS.

SOLUTION: PLOT THE POINTS OF THE GRAPHS OF

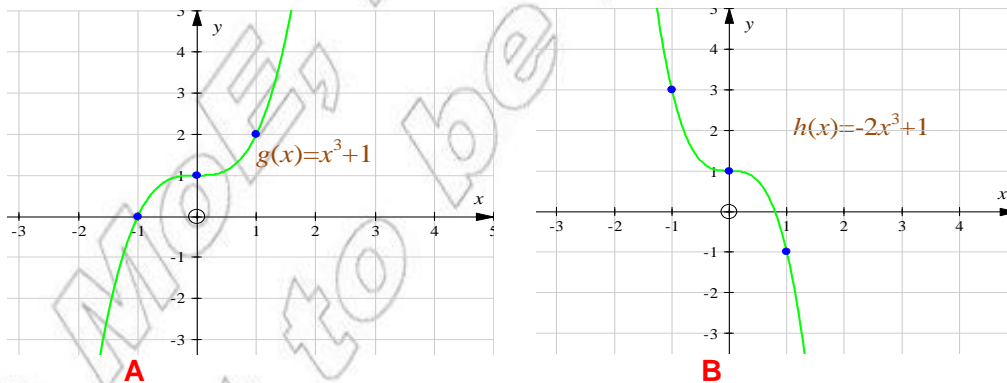

Figure 1.9

AS SHOWN IN FIGURE 1.9, WHEN x BECOMES LARGE IN ABSOLUTE VALUE (AND) IS NEGATIVE BUT LARGE IN ABSOLUTE VALUE (down). WHEN x TAKES LARGE POSITIVE VALUES, $f(x)$ BECOMES LARGE POSITIVE.

IN FIGURE 1.9B, THE COEFFICIENT OF THE LEADING TERM IS -2 WHICH IS NEGATIVE AS A RESULT, WHEN x BECOMES LARGE IN ABSOLUTE VALUE NEGATIVE, $h(x)$ BECOMES LARGE POSITIVE WHEN x TAKES LARGE POSITIVE VALUES, $h(x)$ BECOMES NEGATIVE BUT LARGE IN ABSOLUTE VALUE. THE GRAPH OF $f(x) = a_n x^n + b$ SHOWS THE SAME BEHAVIOUR WHEN n IS LARGE AS THE GRAPH OF g FOR $a > 0$ AND AS THE GRAPH OF h FOR $a < 0$ AND n ODD.

EXAMPLE 5 BY SKETCHING THE GRAPHS OF $g(x) = 2x^4$ AND $h(x) = -x^4$, OBSERVE THEIR BEHAVIOUR AND GENERALIZE FOR EVEN n WHEN $|x|$ IS LARGE.

SOLUTION: THE SKETCHES OF THE GRAPHS OF g AND h ARE AS FOLLOWS.

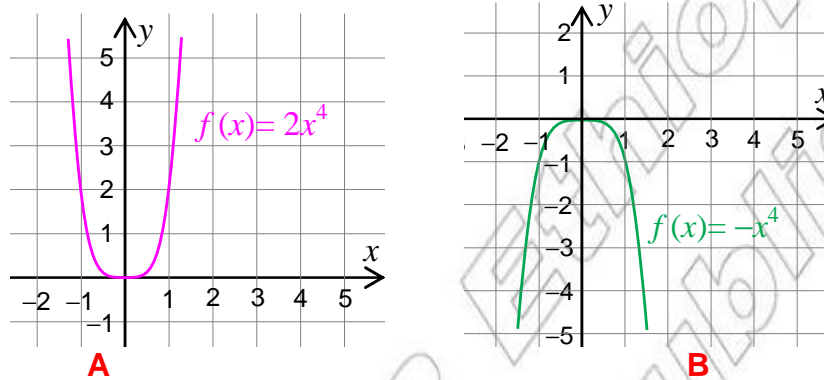
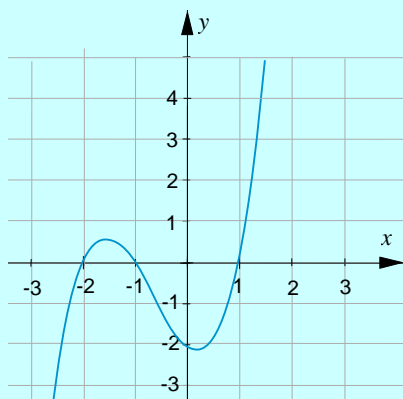

Figure 1.10

FROM FIGURE 1.10A, WHEN $|x|$ TAKES LARGE VALUES, $g(x)$ BECOMES LARGE POSITIVE. ON THE OTHER HAND, FROM FIGURE 1.10B, WHEN $|x|$ TAKES LARGE VALUES, $h(x)$ BECOMES NEGATIVE BUT LARGE IN ABSOLUTE VALUE AND THE GRAPH OPENS DOWNWARD. WHEN n IS EVEN, THE GRAPH OF f OPENS UPWARD, FOR $a > 0$ AND OPENS DOWNWARD, FOR $a < 0$. DRAW AND OBSERVE THE GRAPHS OF $f(x) = 2(x - 1)^4$ AND $h(x) = -(x - 1)^4$.

ACTIVITY 1.13

1 CONSIDER THE FOLLOWING GRAPHS:



A Graph of $g(x) = x^3 + 2x^2 - x - 2$.

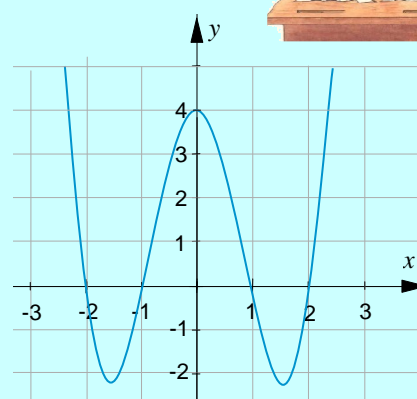

B Graph of $f(x) = x^4 - 5x^2 + 4$.

Figure 1.11

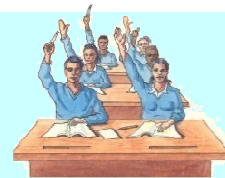

- A** WHAT ARE THE DOMAINS OF
 - B** WHAT CAN BE SAID ABOUT THE VALUES OF $f(x)$ WHEN x IS LARGE AND POSITIVE, OR LARGE AND NEGATIVE?
 - C** IF $x = 2^{10}$, WILL THE TERMS $g(x)$ AND $f(x)$ BE POSITIVE OR WILL THEY BE NEGATIVE? WHAT HAPPENS WHEN
- 2**
- A** DO YOU THINK THAT THE RANGE OF EVERY POLYNOMIAL FUNCTION IS ALL REAL NUMBERS?
 - B** WILL THE GRAPH OF EVERY POLYNOMIAL FUNCTION CROSS THE x -AXIS AT ONE POINT? WHY?

Group Work 1.3



- 1** ON THE GRAPH OF $f(x) = x^4 - 5x^2 + 4$
- A** WHAT ARE THE VALUES OF x AT THE POINTS WHERE THE GRAPH CROSSES THE x -AXIS? AT HOW MANY POINTS DOES THE GRAPH CROSS THE x -AXIS?
 - B** WHAT IS THE VALUE OF $f(x)$ AT EACH OF THESE POINTS OBTAINED IN
 - C** WHAT IS THE TRUTH SET OF THE EQUATION
- 2** CONSIDER THE FUNCTION $f(x) = (x + 2)(x + 1)(x - 1)(x - 2)$
- A** ON THE GRAPH OF THE FUNCTION ARE THE COORDINATES OF THE POINTS WHERE THE GRAPH CROSSES THE x -AXIS?
 - B** DO YOU THINK THE FUNCTION IN QUESTION 1 ABOVE IS THE SAME FUNCTION?
- 3** AS SHOWN IN FIGURE 1.1, THE GRAPH OF THE POLYNOMIAL FUNCTION DEFINED BY $f(x) = x^4 - 5x^2 + 4$ CROSSES THE x -AXIS FOUR TIMES AND THE GRAPH OF $g(x) = x^3 + 2x^2 - x - 2$ CROSSES THE x -AXIS THREE TIMES.
- IN A SIMILAR WAY, HOW MANY TIMES DOES THE GRAPH OF EACH OF THE FOLLOWING FUNCTIONS INTERSECT THE x -AXIS?
- A** $p(x) = 2x + 1$
 - B** $p(x) = x^2 + 4$
 - C** $p(x) = x^2 - 8$
 - D** $f(x) = (x - 2)(x - 1)(x^2 + 4)$.
- 4** DO YOU THINK THAT THE GRAPH OF EVERY POLYNOMIAL DEGREE FOUR CROSSES THE x -AXIS FOUR TIMES?

NOTE THAT THE GRAPH OF A POLYNOMIAL FUNCTION OF DEGREE n HAS AT MOST n REAL ZEROS. SO (AS STATED PREVIOUSLY), EVERY POLYNOMIAL FUNCTION OF DEGREE n HAS AT MOST n REAL ZEROS.

IN GENERAL, THE BEHAVIOUR OF THE GRAPH OF A POLYNOMIAL FUNCTION AS x DECREASES WITHOUT BOUND TO THE LEFT OR INCREASES WITHOUT BOUND TO THE RIGHT CAN BE DETERMINED BY ITS DEGREE (EVEN OR ODD) AND BY ITS LEADING COEFFICIENT.

THE GRAPH OF THE POLYNOMIAL FUNCTION $f(x) = a_n x^n + \dots + a_1 x + a_0$ EVENTUALLY RISES OR FALLS. OBSERVE THE EXAMPLES GIVEN BELOW.

EXAMPLE 6 DESCRIBE THE BEHAVIOUR OF THE GRAPH OF $f(x) = -x^3 + x$ AS x DECREASES TO THE LEFT AND INCREASES TO THE RIGHT.

SOLUTION: BECAUSE THE DEGREE IS ODD AND THE LEADING COEFFICIENT IS NEGATIVE, THE GRAPH RISES TO THE LEFT AND FALLS TO THE RIGHT AS SHOWN IN

FIGURE 1.12. A AND B ARE THE TURNING POINTS OF THE GRAPH OF

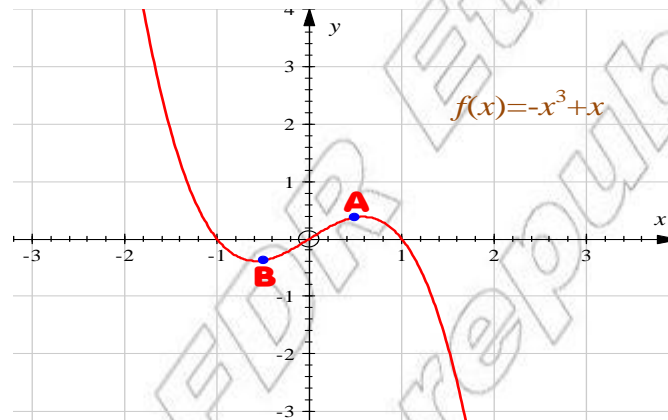

Figure 1.12

FIGURE 1.13 SHOWS AN EXAMPLE OF A POLYNOMIAL FUNCTION WHICH HAS TWO VALLEYS AND TWO PEAKS. THE TERM PEAK REFERS TO A LOCAL MAXIMUM AND THE TERM VALLEY REFERS TO A LOCAL MINIMUM. SUCH POINTS ARE OFTEN CALLED TURNING POINTS OF THE GRAPH.

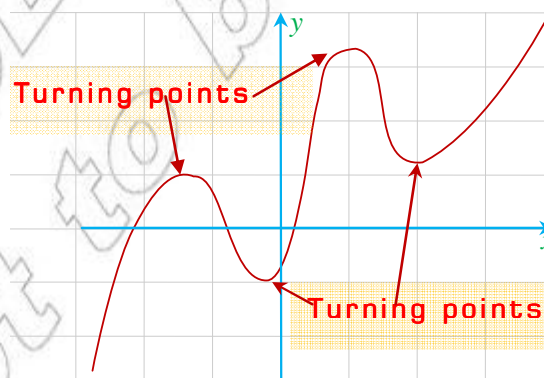

Figure 1.13

A POINT ON A GRAPH THAT IS EITHER A MAXIMUM POINT OR MINIMUM POINT ON ITS DOMAIN IS CALLED A **local extremum point**.

NOTE THAT THE GRAPH OF A POLYNOMIAL FUNCTION CAN BE DETERMINED BY FINDING ITS ZEROS.

EXAMPLE 7 CONSIDER THE POLYNOMIAL

$$f(x) = x(x - 2)^2(x + 2)^4.$$

THE FUNCTION HAS A SIMPLE ZERO AT 0, A ZERO OF MULTIPLICITY 2 AT 2 AND A ZERO OF MULTIPLICITY 4 AT -2, AS SHOWN IN FIGURE 1.14, IT HAS A LOCAL MAXIMUM AT $x = -2$ AND DOES NOT CHANGE SIGN AT $x = -2$. ALSO f HAS A RELATIVE (LOCAL) MINIMUM AT $x = 2$ AND DOES NOT CHANGE SIGN HERE. BOTH $x = -2$ AND $x = 2$ ARE ZEROS OF EVEN MULTIPLICITY.

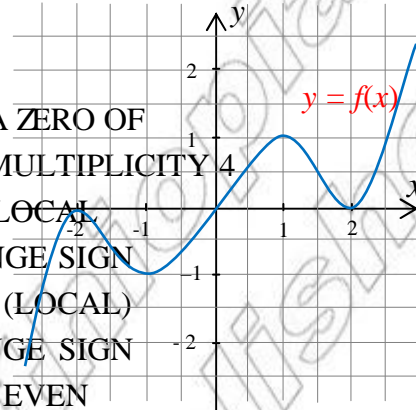

Figure 1.14

ON THE OTHER HAND, A ZERO OF ODD MULTIPLICITY CHANGES SIGN AT THAT POINT AND DOES NOT HAVE A TURNING POINT AT THAT POINT.

EXAMPLE 8 TAKE THE POLYNOMIAL $f(x) = 3x^4 + 4x^3$. IT CAN BE EXPRESSED AS

$$f(x) = x^3(3x + 4).$$

THE DEGREE OF f IS EVEN AND THE LEADING COEFFICIENT IS POSITIVE. HENCE, THE GRAPH OF f RISES UP AS x BECOMES LARGE.

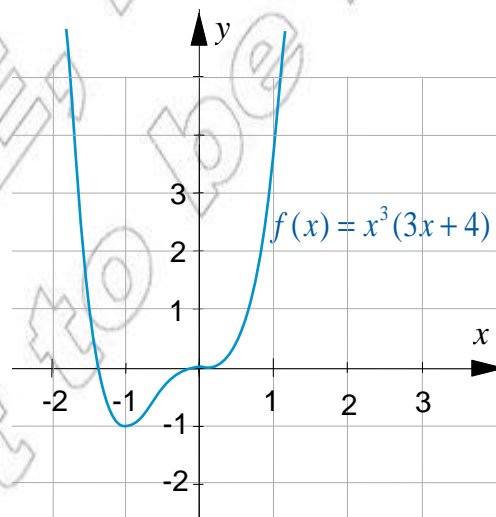

Figure 1.15

THE FUNCTION HAS A SIMPLE ZERO AND CHANGES SIGN AT POINT $\left(\frac{4}{3}, \frac{4}{3}\right)$

THE GRAPH HAS A LOCAL MINIMUM AT POINT $(-1, -1)$.

ALSO HAS A ZERO AT 0 AND CHANGES SIGN HERE. SO, 0 IS OF ODD MULTIPLICITY.

THERE IS NO LOCAL MINIMUM OR MAXIMUM AT $(0, 0)$.

The above observations can be generalized as follows:

- 1 IF c IS A ZERO OF ODD MULTIPLICITY OF $f(x)$, THEN THE GRAPH OF THE FUNCTION CROSSES THE x -AXIS AT $x=c$ AND DOES NOT HAVE A RELATIVE EXTREMUM AT $x=c$.
- 2 IF c IS A ZERO OF EVEN MULTIPLICITY, THEN THE GRAPH OF THE FUNCTION TOUCHES THE x -AXIS AT $x=c$ AND HAS A LOCAL EXTREMUM AT $x=c$.

Group Work 1.4



- 1 GIVE SOME EXAMPLES OF POLYNOMIAL FUNCTIONS AND DESCRIBE THE BEHAVIOUR OF THEIR GRAPHS AS x INCREASES WITHOUT BOUND TO THE LEFT (NEGATIVE BUT LARGE IN ABSOLUTE VALUE) OR AS x INCREASES WITHOUT BOUND TO THE RIGHT (POSITIVE BUT LARGE IN ABSOLUTE VALUE).

DID YOU NOTE THAT FOR $f(x) = a_n x^n + a_{n-1} x^{n-1} + \dots + a_1 x + a_0$, $a_n \neq 0$ IF $a_n > 0$ AND n IS ODD, $f(x)$ BECOMES LARGE POSITIVE VALUES AND BECOMES NEGATIVE BUT LARGE IN ABSOLUTE VALUE AS x BECOMES LARGE NEGATIVE?

DISCUSS THE CASES WHERE:

- | | |
|------------------------------|------------------------------|
| I $a_n > 0$ AND n IS EVEN | II $a_n < 0$ AND n IS EVEN |
| III $a_n < 0$ AND n IS ODD | IV $a_n > 0$ AND n IS ODD |

- 2 ANSWER THE FOLLOWING QUESTIONS:
 - A WHAT IS THE LEAST NUMBER OF TURNING POINTS A POLYNOMIAL FUNCTION CAN HAVE? WHAT ABOUT AN EVEN DEGREE POLYNOMIAL FUNCTION?
 - B WHAT IS THE MAXIMUM NUMBER OF X-INTERCEPTS THE GRAPH OF A POLYNOMIAL FUNCTION OF DEGREE n CAN HAVE?
 - C WHAT IS THE MAXIMUM NUMBER OF REAL ZEROS A POLYNOMIAL FUNCTION OF DEGREE n CAN HAVE?
 - D WHAT IS THE LEAST NUMBER OF X-INTERCEPTS THE GRAPH OF A POLYNOMIAL FUNCTION OF ODD DEGREE/EVEN DEGREE CAN HAVE?

Exercise 1.10

1 MAKE A TABLE OF VALUES AND DRAW THE GRAPHS OF EACH OF THE FOLLOWING POLYNOMIAL FUNCTIONS:

A $f(x) = 4x^2 - 11x + 3$

B $f(x) = -1 - x^2$

C $f(x) = 8 - x^3$

D $f(x) = x^3 + x^2 - 6x - 10$

E $f(x) = 2x^2 - 2x^4$

F $f(x) = \frac{1}{4}(x-2)^2(x+2)^2$

2 WITHOUT DRAWING THE GRAPHS OF THE FOLLOWING FUNCTIONS, STATE FOR EACH, AS MUCH AS YOU CAN, ABOUT:

I THE BEHAVIOUR OF THE GRAPH AS x VALUES FAR TO THE RIGHT AND FAR TO THE LEFT

II THE NUMBER OF INTERSECTIONS OF THE GRAPH WITH THE x -AXIS

III THE DEGREE OF THE FUNCTION AND WHETHER IT IS EVEN OR ODD

IV THE LEADING COEFFICIENT AND WHETHER IT IS POSITIVE OR NEGATIVE

A $f(x) = (x-1)(x-1)$

B $f(x) = x^2 + 3x + 2$

C $f(x) = 16 - 2x^3$

D $f(x) = x^3 - 2x^2 - x + 1$

E $f(x) = 5x - x^3 - 2$

F $f(x) = (x-2)(x-2)(x-3)$

G $f(x) = 2x^5 + 2x^2 - 5x + 1$

3 FOR THE GRAPHS OF EACH OF THE FUNCTIONS GIVEN ABOVE:

I DISCUSS THE BEHAVIOUR OF THE GRAPH AS x VALUES FAR TO THE RIGHT AND FAR TO THE LEFT.

II GIVE THE NUMBER OF TIMES THE GRAPH INTERSECTS THE x -AXIS

III FIND THE VALUE OF THE FUNCTION WHERE THE GRAPH CROSSES THE y -AXIS

IV GIVE THE NUMBER OF TURNING POINTS.

4 IN EACH OF THE FOLLOWING, DECIDE WHETHER IT COULD POSSIBLY BE THE GRAPH OF A POLYNOMIAL FUNCTION:

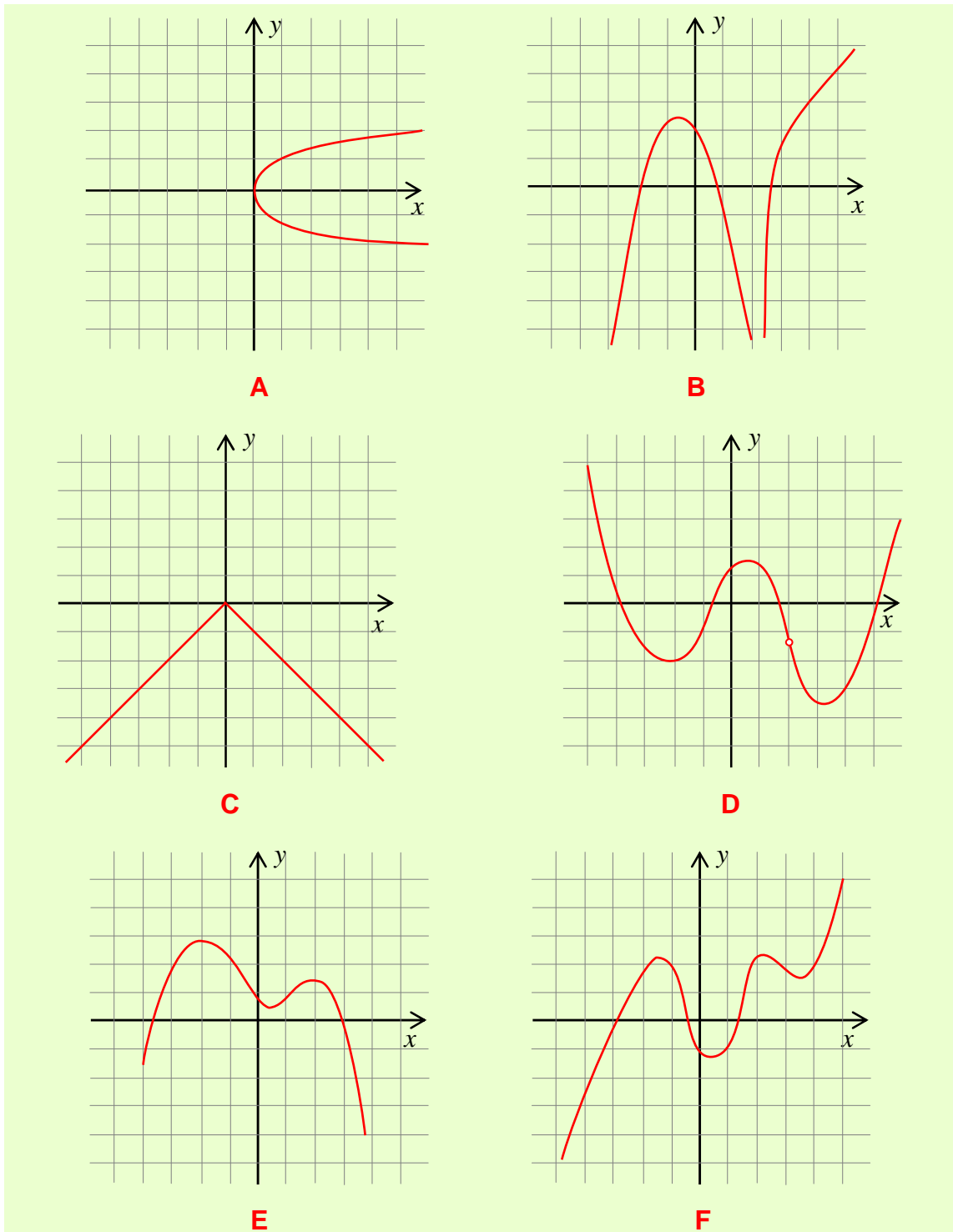
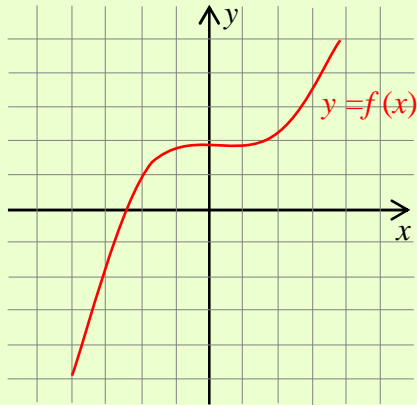

Figure 1.16

- 5** GRAPHS OF SOME POLYNOMIAL FUNCTIONS ARE GIVEN BELOW
- I** IDENTIFY THE SIGN OF THE LEADING COEFFICIENT.

II IDENTIFY THE POSSIBLE DEGREE OF EACH FUNCTION, AND STATE WHETHER THE DEGREE IS EVEN OR ODD.

III DETERMINE THE NUMBER OF TURNING POINTS.



A

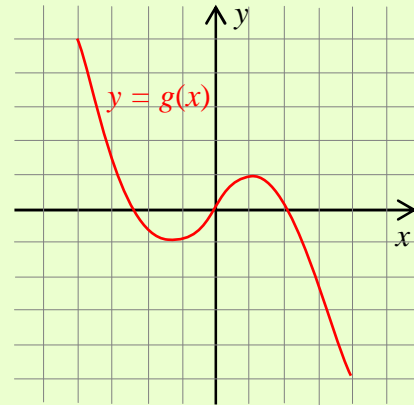

B

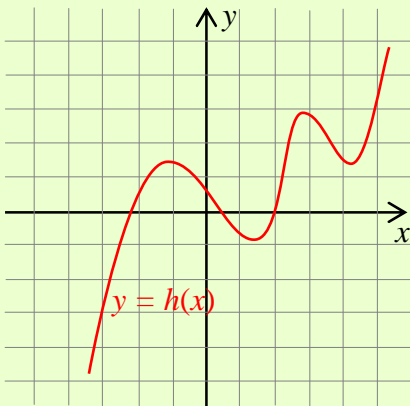

C

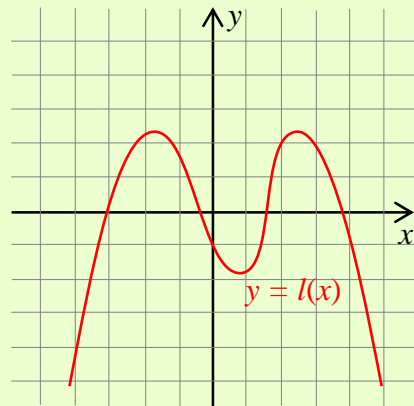

D

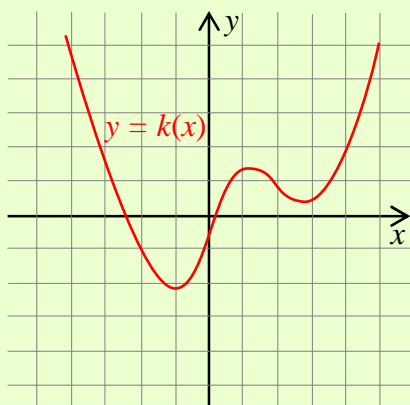

E

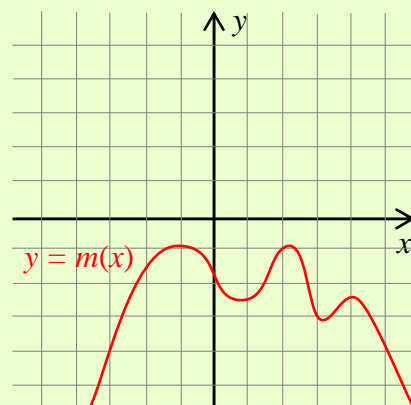

F

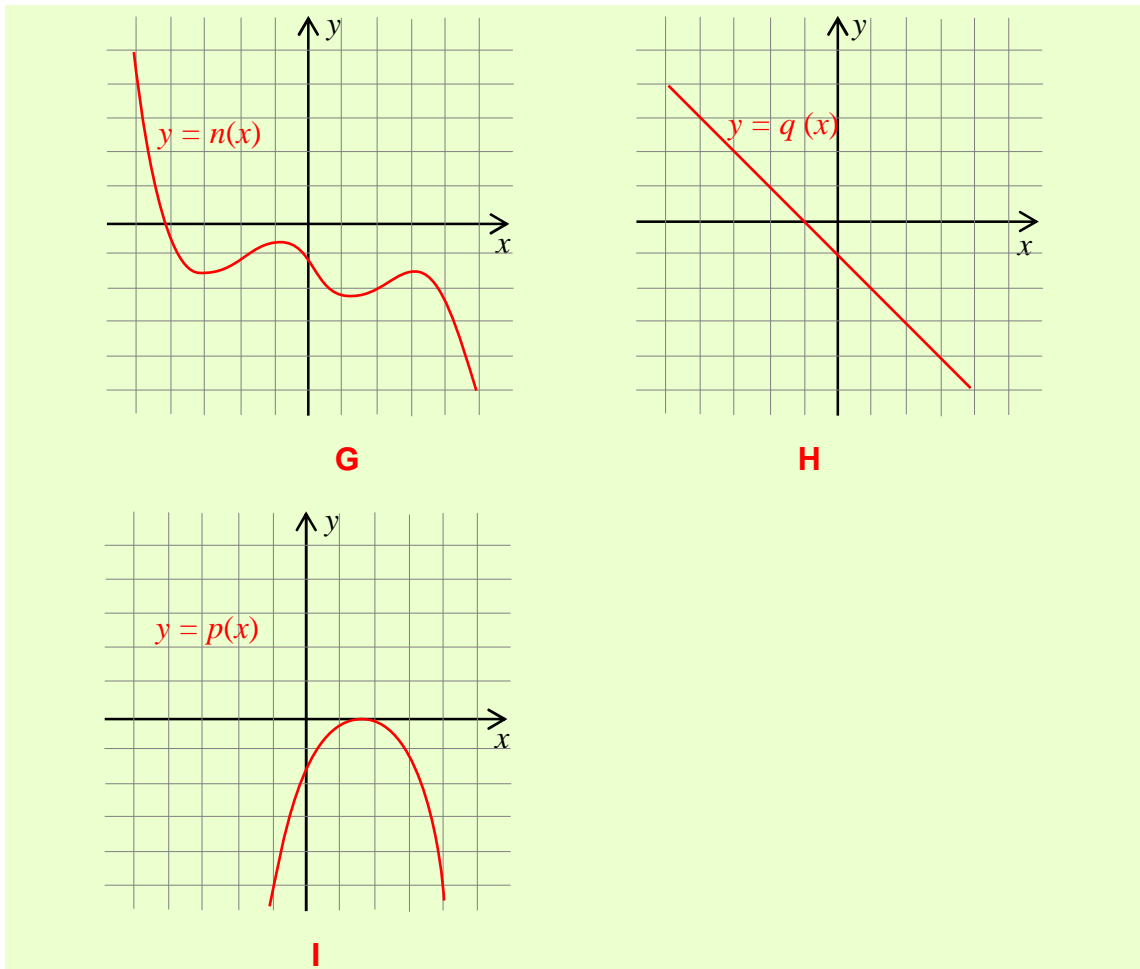

Figure 1.17

- 6** DETERMINE WHETHER EACH OF THE FOLLOWING STATEMENTS JUSTIFY YOUR ANSWER:
- A** A POLYNOMIAL FUNCTION OF DEGREE 6 CAN HAVE 6 TURNING POINTS.
 - B** IT IS POSSIBLE FOR A POLYNOMIAL FUNCTION TO INTERSECT THE x-AXIS AT ONE POINT.



Key Terms

constant function	linear function	rational root
constant term	local extremum	remainder theorem
degree	location theorem	turning points
domain	multiplicity	x-intercept
factor theorem	polynomial division theorem	y-intercept
leading coefficient	polynomial function	zero(s) of a polynomial
leading term	quadratic function	



Summary

- 1 A **linear function** IS GIVEN BY $f(x) = ax + b; a \neq 0$.
- 2 A **quadratic function** IS GIVEN BY $f(x) = ax^2 + bx + c; a \neq 0$
- 3 LET n BE A NON-NEGATIVE INTEGER AND LET a_0 BE REAL NUMBERS WITH $a_n \neq 0$. THE FUNCTION $f(x) = a_n x^n + a_{n-1} x^{n-1} + \dots + a_1 x + a_0$ IS CALLED A **polynomial function in x of degree n** .
- 4 A POLYNOMIAL FUNCTION IS OVER INTEGERS IF ITS COEFFICIENTS ARE INTEGERS.
- 5 A POLYNOMIAL FUNCTION IS OVER RATIONAL NUMBERS IF ITS COEFFICIENTS ARE ALL RATIONAL NUMBERS.
- 6 A POLYNOMIAL FUNCTION IS OVER REAL NUMBERS IF ITS COEFFICIENTS ARE ALL REAL NUMBERS.
- 7 OPERATIONS ON POLYNOMIAL FUNCTIONS:
 - I **Sum:** $(f + g)(x) = f(x) + g(x)$
 - II **Difference:** $(f - g)(x) = f(x) - g(x)$
 - III **Product:** $(f \cdot g)(x) = f(x) \cdot g(x)$
 - IV **Quotient:** $(f \div g)(x) = f(x) \div g(x)$, IF $g(x) \neq 0$
- 8 IF $f(x)$ AND $d(x)$ ARE POLYNOMIALS SUCH THAT $d(x)$ IS LESS THAN OR EQUAL TO THE DEGREE OF $f(x)$ THEN THERE EXIST UNIQUE POLYNOMIALS $q(x)$ AND $r(x)$ SUCH THAT $f(x) = d(x)q(x) + r(x)$, WHERE $d(x) = 0$ OR THE DEGREE OF $r(x)$ IS LESS THAN THE DEGREE OF $d(x)$.
- 9 IF A POLYNOMIAL IS DIVIDED BY A FIRST DEGREE POLYNOMIAL THEN THE **remainder** IS THE NUMBER.

- 10** GIVEN THE POLYNOMIAL FUNCTION

$$p(x) = a_n x^n + a_{n-1} x^{n-1} + \dots + a_1 x + a_0$$
 IF $p(c) = 0$, THEN c IS A **zero of the polynomial** AND A **root** OF THE EQUATION 0. FURTHERMORE, $(x - c)$ IS A **factor** OF THE POLYNOMIAL.
- 11** FOR EVERY POLYNOMIAL FUNCTION AND REAL NUMBER c , IF $p(c) = 0$, THEN c IS A ZERO OF THE POLYNOMIAL FUNCTION
- 12** IF $(x - c)^k$ IS A FACTOR OF $f(x)$, BUT $(x - c)^{k+1}$ IS NOT, WE SAY THAT c IS A **zero of multiplicity k of f** .
- 13** IF THE RATIONAL NUMBER $\frac{p}{q}$ IS THE LOWEST TERM, IS A ZERO OF THE POLYNOMIAL $f(x) = a_n x^n + a_{n-1} x^{n-1} + \dots + a_1 x + a_0$ WITH INTEGER COEFFICIENTS, THEN AN INTEGER FACTOR OF p MUST BE AN INTEGER FACTOR OF a_0 .
- 14** LET a AND b BE REAL NUMBERS SUCH THAT $f(x)$ IS A POLYNOMIAL FUNCTION SUCH THAT $f(a)$ AND $f(b)$ HAVE OPPOSITE SIGNS, THEN THERE IS AT LEAST ONE ZERO OF $f(x)$ BETWEEN a AND b .
- 15** THE GRAPH OF A POLYNOMIAL FUNCTION OF A DEGREE n HAS AT MOST $n - 1$ **turning points** AND INTERSECTS THE x -AXIS AT MOST n TIMES.
- 16** THE GRAPH OF EVERY POLYNOMIAL FUNCTION IS A SMOOTH AND CONTINUOUS CURVE.

? **Review Exercises on Unit 1**

- 1** IN EACH OF THE FOLLOWING, FIND THE **remainder** WHEN THE FIRST POLYNOMIAL IS DIVIDED BY THE SECOND:
- | | |
|--|---|
| A $x^3 + 7x^2 - 6x - 5; x + 1$ | B $3x^3 - 2x^2 - 4x + 4; x + 1$ |
| C $3x^4 + 16x^3 + 6x^2 - 2x - 13; x + 5$ | D $2x^3 + 3x^2 - 6x + 1; x - 1$ |
| E $2x^5 + 5x^4 - 4x^3 + 8x^2 + 1; 2x^2 - x + 1$ | F $6x^3 - 4x^2 + 3x - 2; 2x^2 + 1$ |
- 2** PROVE THAT WHEN A POLYNOMIAL IS DIVIDED BY A FIRST DEGREE POLYNOMIAL $(x - \frac{b}{a})$, THE REMAINDER IS $\frac{b}{a}$.
- 3** PROVE THAT $(x - c)^n$ IS A FACTOR OF $f(x)$ WHERE n IS AN ODD POSITIVE INTEGER.
- 4** SHOW THAT $\sqrt{2}$ IS AN IRRATIONAL NUMBER.
Hint: $\sqrt{2}$ IS A ROOT OF $x^2 - 2$. DOES THIS POLYNOMIAL HAVE ANY RATIONAL ROOTS?
- 5** FIND ALL THE RATIONAL ZEROS OF:
- | |
|--|
| A $f(x) = x^5 + 8x^4 + 20x^3 + 9x^2 - 27x - 27$ |
| B $f(x) = (x - 1)(x(x + 1) + 2x)$ |

6 FIND THE VALUE OF k SUCH THAT:

A $2x^3 - 3x^2 - kx - 17$ DIVIDED BY 3 HAS A REMAINDER OF -2 .

B $x - 1$ IS A FACTOR OF $x^2 + 2kx - 3$.

C $5x - 2$ IS A FACTOR OF $x^2 + kx + 15$.

7 SKETCH THE GRAPH OF EACH OF THE FOLLOWING:

A $f(x) = x^3 - 7x + 6; -4 \leq x \leq 3$

B $f(x) = x^4 - x^3 - 4x^2 + x + 1; -2 \leq x \leq 3$

C $f(x) = x^3 - 3x^2 + 4$

D $f(x) = \frac{1}{4}(1-x)(1+x^2)(x-2)$

8 SKETCH THE GRAPH OF THE FUNCTION $g(x)$. EXPLAIN FOR EACH OF THE FOLLOWING CASES HOW THE GRAPH DIFFERS FROM THE GRAPH OF $f(x)$. DETERMINE WHETHER g IS ODD, EVEN OR NEITHER.

A $g(x) = f(x) + 3$

B $g(x) = f(-x)$

C $g(x) = -f(x)$

D $g(x) = f(x + 3)$

9 THE POLYNOMIAL $f(x) = A(x-1)^2 + B(x+2)^2$ IS DIVIDED BY 1 AND -2 . THE REMAINDERS ARE 3 AND -15 RESPECTIVELY. FIND THE VALUES OF A AND B .

10 IF $x^2 + (c-2)x - c^2 - 3c + 5$ IS DIVIDED BY c , THE REMAINDER IS -1 . FIND THE VALUE OF c .

11 IF $x - 2$ IS A COMMON FACTOR OF THE EXPRESSIONS $(m+n)x - n$ AND $x^2 + m(-1) + m + n^2$, FIND THE VALUES OF m AND n .

12 FACTORIZE FULLY:

A $x^3 - 4x^2 - 7x + 10$

B $2x^5 + 6x^4 + 7x^3 + 21x^2 + 5x + 15$.

13 A PSYCHOLOGIST FINDS THAT THE RESPONSE TIME R IN MICROSECONDS IS RELATED TO AGE GROUP y IN YEARS ACCORDING TO

$$R = y^4 + 2y^3 - 4y^2 - 5y + 14,$$

WHERE R IS RESPONSE IN MICROSECONDS, IS AGE GROUP IN YEARS. FOR WHAT AGE GROUP IS THE RESPONSE EQUAL TO 8 MICROSECONDS?

14 THE PROFIT OF A FOOTBALL CLUB AFTER TAKEOVER IS MODELLED BY

$$p(t) = t^3 - 14t^2 + 20t + 120,$$

WHERE t IS THE NUMBER OF YEARS AFTER THE TAKEOVER. IN WHICH YEARS WAS THE CLUB MAKING A LOSS?